

1940

Radio

SERVICE DEALER

SOUNDMAN * JOBBER

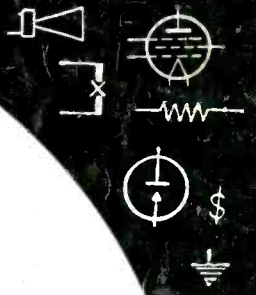

20¢

P. R. MALLORY & CO., Inc.

MALLORY

Roots You Deeply Into the Soil of Profits



Mallory Replacement Vibrators, Condensers, Volume Controls and other replacement parts enjoy a long-standing reputation for trouble-free operation and long life that has been won in actual service.

Mallory's leadership begins with the set manufacturers who use Mallory products for original equipment. They are the "who's who" of the radio industry and their specification of Mallory products is a tribute of which any parts manufacturer could be proud.

In the replacement field, Mallory's leadership is equally wide

because radio service engineers have learned that they can depend upon Mallory for complete customer satisfaction.

Mallory has brought standardization to many items that has immeasurably simplified installation. This has led directly to lower inventory investment with faster turnover . . . and to faster, easier, more profitable service work. Follow the formula of thousands of successful service men. Insist on the best . . . it costs no more . . . Mallory's nation-wide, selected distributor setup is equipped to give you tops in service.

Use

P. R. MALLORY & CO., Inc.

MALLORY

APPROVED
PRECISION PRODUCTS

P. R. MALLORY & CO., Inc.
INDIANAPOLIS INDIANA

Cable Address—PELMALLO

Radio

SERVICE-DEALER

SOUNDMAN AND JOBBER

Ad Index

Alliance Mfg. Co.	27
"Even-Speed" Phono-Motors	
American Radio Hardware Co., Inc.	29
Radio Hardware	
Bank's Mfg. Co.	12
Intercommunicators	
Centralab	3rd Cover
Volume Controls	
Clarostat Mfg. Co., Inc.	27
Volume Controls, Service Manual	
Guardian Electric Co.	30
Antenna Relays	
Lifetime Corp., The	28
Trumpets, Speaker Units	
Mallory & Co., P. R.	2nd Cover
Vibrators, Condensers, Volume Controls	
Meissner Mfg. Co.	23
Frequency Modulation Receptor	
Nat'l Radio Parts Distributors Assoc.	31
Dinner Meeting	
Ohmite Mfg. Co.	30
Resistors	
Racon Electric Co.	25
Horn and Cone Speakers	
Raytheon Production Corp.	9
Tubes	
RCA Manufacturing Co., Inc.	16-17
Preferred Type Tubes	
Radio Servicemen of America	32
Membership	
Solar Mfg. Corp.	29
Red-Caps (Condensers)	
Supreme Instruments Corp.	11
Tube, Battery & Set Testers	
Triplett Electrical Inst. Co., The	20
Model 1632 Wide-Range Signal Generator	
Ward Products Corp.	4th Cover
Signal Boosters, Flex-angle Antennas	

Contents

Profits For You In Master Antenna Systems	4
By Carl Goudy	
Instantaneous Sound Recording, Part II	6
By F. H. Goldsmith	
Help Standardize Dry-Cell Types	8
Serviceman's Dairy	10
By J. P. Hollister	
Horace (Cartoon Strip)	10
Technical Service Portfolio: Section II—Test-Oscillator Applications	13
Circuit Court:	
F-M Alignment	19
Volume Indicator for P.A.	19
Termination Impedance	19
Shop Notes:	
Crosley 689, 729 Alignment Precaution	21
Stromberg-Carlson 460-PF Phono Compensation	21
Stewart-Warner 01-6C9, 010-6C9X Tone Control Changes	21
Stewart-Warner Wiring Color Code	21
Wells-Gardner 5D2, 6A26, 6A27 Hum Reduction	21
Presenting—New Products	22, 24, 26
Catalogs—Bulletins	23
Sales Appointments	23
Hudson Motor Vacuum Antenna Installation	29

Cover Photo



★ Servicemen installing a master antenna system atop an apartment building. Note that they wear safety belts—a worthwhile precaution when working on tall buildings. See article on page 4. (Photo by Austin C. Les-carboursa)

Published Monthly by

COWAN PUBLISHING CORP.

11 WEST 42nd ST., NEW YORK, N. Y.

Telephone: CHickering 4-3278-9

M. L. MUHLEMAN, EDITOR
S. R. COWAN, ADV. MANAGER

Subscription rate, \$2.00 a year in U. S. and Canada; single copies, 20 cents. In foreign countries, \$4.00 a year. Editorial and advertising offices, 11 West 42nd St., New York, N. Y.

VOL. 1 No. 3 ★ JUNE, 1940

Copyright, 1940, Cowan Publishing Corp.

The July Issue of

Radio

SERVICE-DEALER

will be **HOT!**

The editorial staff will review the galaxy of New Radio Products, Test and Sound Equipment, Electronic Devices and Accessories which have been announced and introduced at the National Radio Parts Manufacturer's Annual Trade Show.



All radio service-dealers (except those who are already paid subscribers) should make sure that they receive a copy of our July, and every subsequent, issue. The vitally important data each issue will contain is *exclusive* and timely . . . edited for the prime purpose of helping each community's outstanding service-dealer **MAKE MORE MONEY.**

RSD is a new magazine—this being the third issue. But, in a sense, it is the oldest technical serviceman's monthly publication because both the editorial and advertising staffs were the pioneers in the field. In three short months RSD has blazed new trails emerging from this long background of experience.

Having won the acceptance and support of the Radio Industry's foremost manufacturers, service-dealers, soundmen and jobbers . . . we invite you to grow with us. Remember, your Jobber told us that you are an outstanding servicer in your community. Even though you do not subscribe to RSD copies will be

sent to you six or seven times a year without cost or obligation. However, to insure yourself of having every one of the twelve issues published during a year, it will be necessary for you to become a paid subscriber. Take advantage of the introductory, half-price subscription rates now in effect.* By so doing 12 issues will cost only \$1. (less than 9c per month). Use the pink postage-paid envelope which is bound into the center spread of this issue.

It is RSD's policy to accept paid subscriptions from only outstanding service-dealers in any community and not from experimenters and part-timers whose unsound, unethical, price-cutting business tactics have in general jeopardized the status of legitimate, industrious service-dealers everywhere. We offer you no premiums or bonuses in order to obtain your subscription. Each issue of RSD in itself is worth more than the annual subscription price . . . and a file of RSD, if kept complete, will prove invaluable for many years to come.

No subscriptions are accepted without complete data as to your status in the field thus entitling you to the half-price subscription rate. (Annual subscriptions from a very limited number of part-time, qualified servicemen or students enrolled in accredited schools with radio courses will be accepted at \$2.00 each for 12 issues of RSD at the publisher's option.)

***Regular Annual Subscription Price for 12 issues of Service-Dealer is \$2 (FOREIGN \$4)
By Filling in the Pink Coupon Envelope You May Subscribe Now for \$1.00
The Introductory, Half-Price Rate Offer will Expire Soon . . . Hurry!!**

Transients

F. M. . . . The F.C.C. has assigned forty channels in the 42-50 megacycle band to an unlimited number of frequency-modulation broadcast stations. This band includes what was heretofore Television Channel No. 1. Of these forty channels, thirty-five will be open for commercial and five for non-commercial stations.

There are pending over 130 applications for full-time commercial f-m stations, with an average power of 1 kilowatt. If all of these applications are granted, there will soon be around 150 f-m stations on the air—a very impressive beginning for Major Armstrong's brain child.

Of interest to the serviceman is the fact that the majority of these applications have come from "little business" in towns and cities of comparatively small population, and that these applications are well distributed geographically. We are to witness, therefore, not merely the blossoming of a new era in broadcast transmission technique, but the emergence of typical "home-town" influence via the air waves. Until now, the overcrowded condition of the standard broadcast band has kept the little fellow off the air; the advent of f-m broadcasting provides him with the opportunity he has long awaited. Since inter-station interference is hardly a problem in f.m., the degree of station expansion is practically unlimited.

The first indication of the implication that f-m broadcasting is a national rather than a sectional affair, is the advertisements of Stromberg-Carlson Frequency-Modulation Receivers appearing in such magazines with national distribution as *The Saturday Evening Post*. We may take this as a sign that the servicing of f-m receivers will not be confined to a few large cities; indeed, it may be expected shortly in a vast number of areas throughout the country.

We would like to point out that a large part of the servicing of f-m receivers will revolve around adjustment rather than repair. Precise alignment is an essential, and slight departures from on-the-nose adjustments will have a far greater effect on tonal quality and noise level than is the case in an a-m receiver with a comparatively narrow acceptance band.

This being the case, servicemen in

areas served by f-m stations will find there is a special opportunity in the maintenance of the broadcasting service from the reception end. Since it is of extreme importance to the owners of f-m stations that each member of the listening audience derives the maximum benefit from his receiver, the owners will be quick to grasp at any cooperative arrangement with top-notch servicemen that will insure this objective.

As a cooperative arrangement, stations should solicit complaints and turn them over to servicemen in the localities from which the complaints come. Or supply the servicemen with the names of f-m set owners.

★

OFF THE AIR . . . Servicemen and soundmen who have instituted instantaneous sound-recording services in towns and small cities boasting a local broadcast station, should not overlook the possibilities in off-the-air recording. True, many stations have their own recording service for the benefit of those who go on the air and may wish a lasting record of their talents, but there is still room in the business for the freelance recordist.

The legal aspects are quite simple—one may record anything he wishes off the air, but he cannot sell the recording or use it commercially unless permission to do so is granted by the originator. A recordist may therefore make a cutting from a broadcast speech, for instance, and offer it for sale to the author of the speech, or he may contract for a recording of the speech before the broadcast takes place. Obviously, the latter method is the least expensive. The station programs provide the prospect list.

Since duplicates of good quality are easily made from an original by re-recording, the recordist is given the same scope as a commercial photographer. Where the photographer sells numerous prints of a gathering, the recordist can sell numerous records of a glee club, a forum, a home-town orchestra, or any other group broadcast. Each participating member is a prospect.

One other opportunity presents itself: re-recording, on order, for broadcast stations where the recording equipment

must be used exclusively for making originals during on-the-air time.

★

GADGETEERS . . . The field of electronics is an outgrowth of the field of radio. It may be defined as the industrial application of radio principles. Electronics itself is an ever-expanding medium and a highly profitable one. From the viewpoint of the layman, it is anything that involves the use of a photoelectric cell. We know that it involves considerably more than that.

By far the largest number of electronic devices that have found service in the industrial field come under the classification of "gadgets"; i.e., units made up of a group of radio parts and invariably including a vacuum tube if not a photo-cell. To the uninitiated, they are marvels of modern science, and their design unquestionably the work of super-engineers. On the other hand, we know that most of these devices are no such thing—at least from our viewpoint. On the whole, their functioning is based on far simpler circuit actions than the serviceman is accustomed to checking in his regular routine. To the serviceman, the manner in which these electronic devices operate is, to use an old phrase, "simple as all get-out."

Having a knowledge of electronics, the serviceman is in a position to install as well as design electronic devices. He is the logical man to undertake the solution of industrial problems by electronic means in his own locality. He is, in short, the one and only Electronic Gadgeteer.

Consider this merely as an introduction to a subject that holds bright possibilities for any serviceman who knows his stuff. We'll be treating it more elaborately in our text pages, beginning next month.

★

POST-SHOW . . . Don't miss the July issue. There'll be a complete report on the Radio Parts National Trade Show, to be held in Chicago from June 11th to 14th inclusive. That's where the coming year's pace will be set, where the new ideas will emerge, where the new lines will be introduced. We'll give you the works.

—EDITOR

PROFITS FOR YOU IN

IF you are interested in picking up a good many extra dollars, then you're vitally interested in this master-antenna-system business. In your own community, as in thousands of other communities, there are countless opportunities to make anywhere from a few dollars to several hundred dollars per job. The work is simple. Gamble has been eliminated. Competition is conspicuous by its very absence. Prices are right. Profits are assured. And it all sums up to a mighty nice business which should not be passed up—so let's investigate the facts.

THE SYSTEM

A master-antenna-system is simply a noise-reducing system serving a plurality of sets. One aerial may thus be made to serve up to 25 sets. If more sets are to be served, additional aerials and transmission lines are installed on the basis of one to every 20 or 25 set outlets.

Primarily intended for the radio needs of the city apartment house, the hospital, the club house, the hotel or any other public building with a number of radio sets in use, the master antenna system also serves the private dwelling in which several radio sets are used. Indeed, the private house applications have grown to a surprising extent of late. This field, perhaps more than the public building field, is immediately attractive to any live-wire serviceman.

EXPOSED WIRING JOBS

There are two general kinds of master-antenna-system installations. First, there's the concealed wiring job, in which the transmission line is run through conduit and the coupling units for outlets are placed in conduit boxes. That, very frankly, is the electrical contractor's domain. We're not going to step into his field. Servicemen can, however, and often do, take care of the aerial or roof

* Chief Engineer, Technical Appliance Corp.

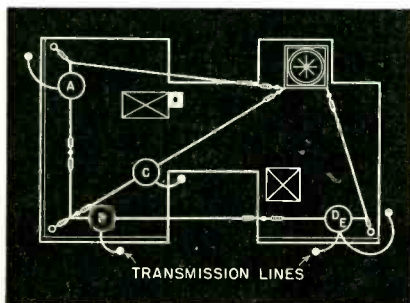

Typical 5-aerial roof layout—the sort of sketch you should make after survey of property. Note how full use is made of water tower as support, with masts for other supports.

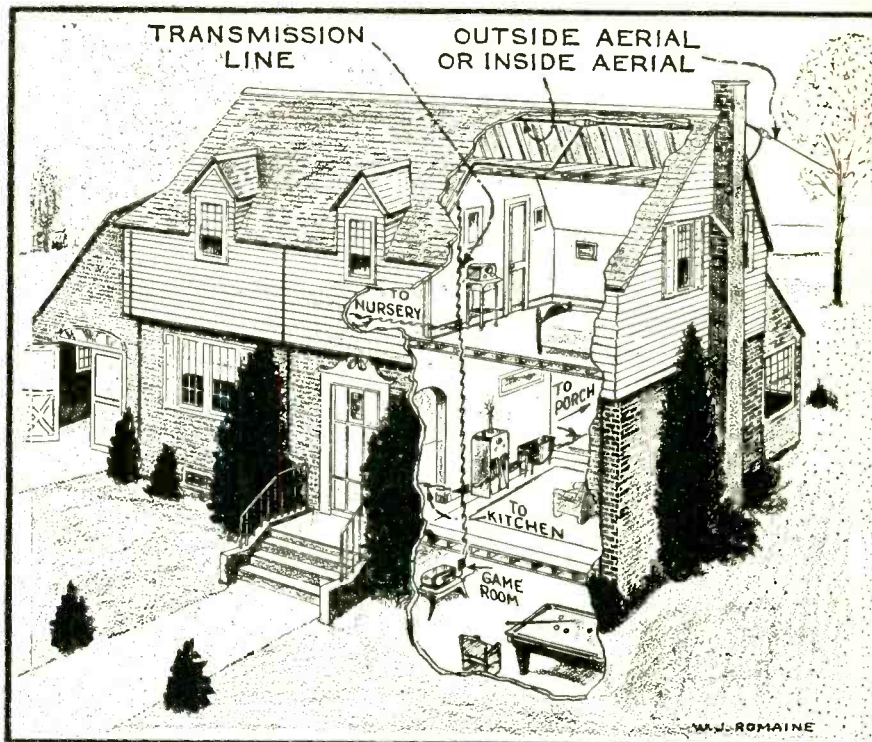

Master antenna installation for private dwelling. Aerial may be swung in attic or strung outdoors.

end of the installation, because that's really a radio job and rightfully belongs to a serviceman. The electrical contractor and the serviceman can get together very nicely on the concealed-wiring installation.

Concealed wiring installations are intended for new buildings. The conduit is installed before the walls are plastered or otherwise closed in. But when it comes to existing buildings—and that happens to be the major portion of potential installations—the wiring is entirely exposed on the outside walls, and the job can be rightfully considered the serviceman's own work. The transmission line, dropped down and supported a few inches away from an outside wall, is tapped at each floor for connections with the set coupling unit which is mounted on the inside window sill. The whole job is simple, neat, economical.

So let's get this proposition straight right now. As a serviceman, you can tackle the entire *exposed-wiring* installation for old buildings or new. As a serviceman you can work hand in glove with an electrical contractor, doing the aerial work while the electricians do the conduit wiring, for the concealed-wiring job.

KNOW YOUR COSTS!

Of course, most master-antenna-system jobs must be estimated. The property

owner wants a figure in advance. But that's nothing to be scared about. The installation comprises simply materials and labor. Since standardized components and materials are used, you can get your material costs figured out to within a few dollars even on the more ambitious jobs.

Each aerial comes as a so-called roof kit—wire, transformer unit, lightning arrester, insulators—at a fixed price. The supports are easily figured. If you can



How a water tower on the roof is used as a support for a multi-aerial master antenna system.

MASTER ANTENNA SYSTEMS

By **CARL GOUDY***

use existing roof superstructures, such as water towers, flagpoles, cornices, etc., there's nothing to be added for material. But if you require poles for supports, you can get your costs on standard iron-pipe masts to provide proper clearance of 10 feet above the roof. It is best to use a 15-foot pipe, five feet of which is used for supports as shown in one of the accompanying sketches. Your local plumbing-supply house or plumber will quote exact costs. Note, too, the cost of the elbow, T, cap and fittings required. All standard items. All definitely priced.

The transmission line also is readily figured. The twisted pair cable costs so much per foot. You know how many feet you have to run from the aerial on the roof to the lowest floor of the build-

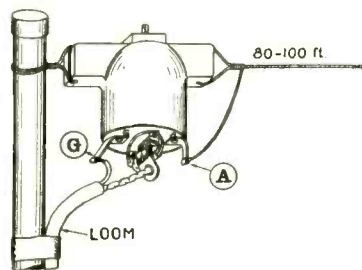

A Taco coupling unit. Note simplicity of connections and installation.

ing. Simply a matter of multiplication. Add a little for porcelain knobs to act as stand-off insulators, a roll or two of friction tape, a few cents for solder and flux, and you've got that part of the job figured out.

Then the set outlets. These come with the necessary connecting cable to the transmission line. Set outlets are a standard item, costing so much each. Again simple multiplication.

There are a handful of extras which must be covered by allowing, say, an extra ten dollars for the single aerial installation, to cover incidentals such as tape, screws, nails, clamps, etc. If some of the wiring is to be buried in slots which must be subsequently filled in with tar or waterproof compound, allow for such extras.

When we come to the labor costs, here you'll have to draw largely upon your own experience. You've handled antenna jobs before. You have a pretty good idea how long it takes to string up a simple aerial. You know how long it takes to string up a transmission line, make connections for the given number

of outlets, how long it takes to bore a hole through the window frame to connect with the coupler outlet screwed on the inside window frame. There shouldn't be much gamble here. The first job or two will have to be estimated rather widely to allow for your unfamiliarity with the details of such work. But after the first job or two, you can gather labor costs rapidly and figure very closely on subsequent installations.

If you are doing all the work yourself, you don't have to figure in compensation insurance. You should, however, figure something for accident insurance. It's a legitimate part of your own labor cost. You're foolish if you don't carry some sort of accident insurance to protect you and yours in the event of a mishap. And if you're hiring people to do this kind of work, by all means carry compensation insurance, at least for each job. Your local insurance agent will give you the exact figure for the job. Include that with your labor charges.

To help you estimate material and labor costs, the accompanying simple cost-estimating forms are presented. You can use similar forms in working out estimates.

MAKE THOROUGH SURVEY

Once you know what the costs are in this kind of work, you are ready to submit estimates to interested owners following a thorough survey of their prop-



Serviceman working with small electric jack hammer, boring holes in masonry. Note safety belt.

erty. The procedure here is much like that of the electrician figuring on wiring. Ask for floor plans of the building, if available. Determine the location of the radio outlets. Go over the roof and check for available superstructure supports if any, and for masts if required. Determine how the aerial or aerials will be strung, how transmission line or lines are to run, and other essential details. Measure exact distances, spans, runs. (Turn to page 28)

ESTIMATED MATERIAL					
	Number Used	Unit Cost	Total Cost		
Foundation Units					
Couplers					
Transmission Line (305, 306)					
Mast Assemblies					
Porcelain Knobs					
No. 14 R.C. Solid Wire					
Miscellaneous					

ESTIMATED LABOR COST					
OPERATIONS	Man-hour operation (A)	Cost per man-hour (B)	Cost per operation (C) A X B	Units used (D)	TOTAL C X D
Handling of Material					
Mounting of Mast					
Erection of Aerial					
Mounting Lightning Arrestor					
Embedding of Wires					
Mounting of Knobs					
Installing Couplers					
Testing					

Simple estimate sheets of this sort will assist you in accurately computing all costs.

INSTANTANEOUS

PART II

RECORDING, being a relatively new field of development, has left the serviceman in the position of having new problems presented to him without having been supplied the necessary technical information on which to build his groundwork of test procedure. The electrical devices used in recording do not present any radically new ideas that require intensive study except in a few isolated cases. The serviceman who has devoted a little time to audio amplifier work is quite capable of analyzing the electrical circuits involved in a recording device and should not feel stumped when presented with a recorder that is not operating.

The audio amplifier portion of the instantaneous recorder differs in most part from that of a modern radio chassis only in the matter of amplification or gain, when a microphone is used. Switching devices are less complicated than may be thought on first examination. The output circuits may or may not contain compensation for the recording head, depending on the type that is used.

LEVEL INDICATORS

The recording level indicator incorporated in the output circuit is simply a means of indicating the output voltage of the amplifier and is adjusted so that the cutting head will record a sound level that has been accepted as a satisfactory compromise between minimum surface noise and maximum volume permissible on the record. The most common level indicators for home recorders are a pair of neon tubes or lamp bulbs, as shown in Fig. 1A. One indicates proper volume level and the other indicates "overcutting." Service instructions specify the voltages at which each tube should glow. It is important to pay particular attention to the meter resistance used to obtain the measurements, as most level indicators

are placed in a high-impedance circuit, necessitating the use of a vacuum-tube voltmeter for measurement.

Those recorders that employ a "magic eye" for volume indication, as shown in Fig. 1B, use the eye in one of two ways; either as a measurement of straight a-c voltage of the power being fed to the recording head, or as a measurement of the rectified component of the same voltage. When used as an a-c meter, the eye will read instantaneous peak voltage; when used as a d-c meter, there will be imposed a considerable delay and only the average values will be indicated.

Where meters are used as volume indicators, as shown in Fig. 1C, they are usually of the rectifier type and as such require no further explanation.

RECORDING HEADS

The recording head is a device probably new to most servicemen. There are two types in widespread use today; the crystal and the magnetic types. Both are remarkably efficient and yet comparatively inexpensive. The crystal recording head operates on one proven theory, the magnetic type on another proven theory. Quality of construction in a recording head is more important than it is in any other part of the recording system, for this is the device that transforms electrical energy into mechanical energy and upon it largely depends the quality of the recording.

The crystal recording head operates in approximately the same way as does the crystal pickup. The element is a slat of Rochelle Salt crystal rigidly held at one end and allowed to move with restricted freedom at the other, as shown in Fig. 2. The crystal element is of the torque type that has the property of "twisting" when electrical energy is applied to it in the proper manner.

The serviceman can make no adjust-

ments or repairs to a crystal cutting head, nor can anyone else, except the manufacturer. If a crystal head is not performing satisfactorily, it must be replaced.

It is wise to remember some of the inherent qualities of crystal devices before passing judgment on cutters of this type. Operating temperature has considerable effect on their performance, which is best at about 70 degrees Fahrenheit. Temperatures below 70 degrees will cause an increase in bass response while the treble remains reasonably constant. Temperatures above 70 degrees will cause a loss of bass response. Low temperatures will not have a permanent effect on the crystal, but temperatures very much higher than 90 degrees will damage it seriously, and if exposed too long will destroy the crystal completely. Humidity conditions also have an adverse effect on crystals. All possible precautions are taken to make the crystal element as moisture-proof as possible, but even this is sometimes not enough. If your particular location is subject to conditions of high humidity you may have some difficulty with crystal units.

When the possibility is considered of replacing crystal devices with magnetic ones, it is wise to recall the foregoing remarks regarding quality. An inferior magnetic device is not going to be any improvement at all.

An examination of the constructional details of a magnetic recording head is well worth the time and trouble. The recording heads you are wise to stay away from are those that use a large rubber pad for damping, a rubber housing and altogether are made just like the older types of magnetic pickups.

Magnetic recording heads can be affected by temperature variations just

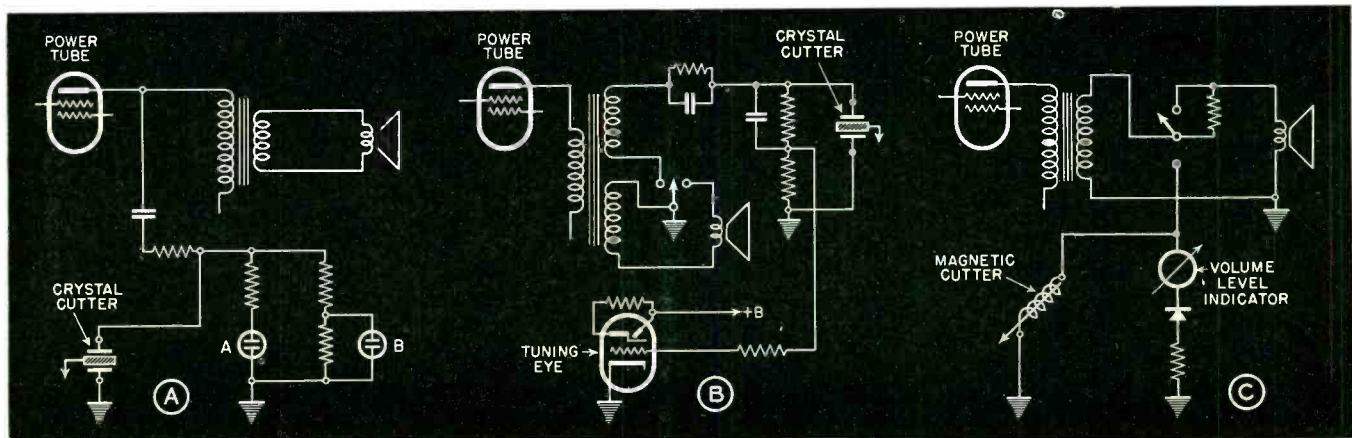

Fig. 1. Three types of volume-level indicator: (A) neon tubes or small lamps; (B) electron-ray tube; (C) meter.

SOUND RECORDING

By F. H. GOLDSMITH

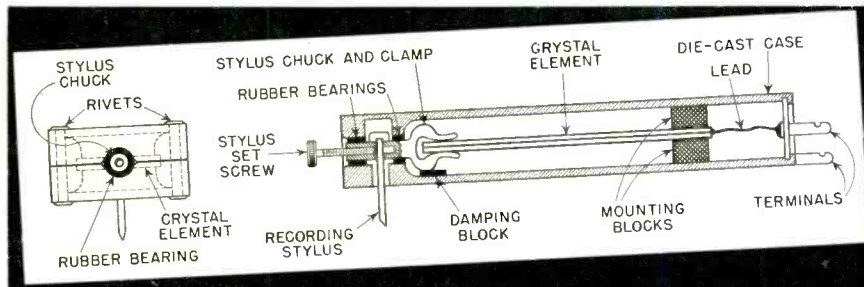

Fig. 2. Details of a typical crystal cutting head.

as can the crystal types. Large amounts of damping material always indicate poor design and wide variation with temperature. A thin armature always foretells high distortion. Possibly the best indication as to the value of a magnetic recording head is the reputation of the manufacturer.

The frequency response range of a recording head is of extreme importance. The upper frequency limit for home recorders lies at about 5000 cycles. This is not limited strictly by the recording head, but is also a function of the recording blanks used.

The function of a recording head is of a definite and invariable nature. Regardless of the type of electrical "motor", the recording stylus, when properly attached, must be driven in a single plane of motion.

Practically all types accomplish movement of the recording stylus by a leverage action. In the case of the crystal recording head, illustrated in Fig. 2, motion is imparted to the stylus through the crystal element clamp. The high-frequency response depends upon the stiffness and mass of the clamp, chuck stylus and screw. Fidelity or freedom from distortion, depends on the mechanical alignment of the vibrating elements with the crystal and in the "fit" and alignment of the bearings.

A magnetic recording head operates on exactly the same theory as a magnetic reproducer and in exactly the same way. (Fig. 3). It does not follow that a good reproducer design is at all acceptable as a recording head, for the electrical-mechanical transformation is reversed and the various components of mass stiffness, or compliance and damping are different in their requirements.

RECORDING TURNTABLES

The basic requirements of a recording turntable are speed constancy, free-

dom from "flutter" and rumble, and sufficient torque to maintain an absolute speed when recording as well as reproducing. The recording speed must be exactly the same as the reproducing speed despite the difference in "drag" of the recording stylus and if present standards are to be maintained, it must revolve at exactly 78.26 or 33 1/3 rpm, as the case may be.

The recording turntable assembly is incorporated in most home recorders and, therefore, is subject to considerable variation. Many of the defects that are encountered in home recorders at present can be directly traced to the recording mechanism rather than to any electrical defect.

In the preceding article several photographs were shown which visually illustrate some of the audible defects and will be quite commonly encountered in service work. The following tabulation of service problems should be useful in correlating your experience with that of other servicemen.

SERVICING PROBLEMS

There are a number of problems in conjunction with recording technique with which the serviceman should be acquainted. The following are particularly important:

Surface Noise: In the event that a recording has a high degree of surface noise, it is more than likely due to the use of a dull recording stylus, poor grade recording blank or an improperly installed recording stylus. All three of these conditions are easily checked by experiment.

Squealing: If a high-pitched squeal is produced, first try readjusting the stylus vertical angle, and if this does not remove the difficulty, install a new cutting stylus.

Hum: Apparent 60- or 120-cycle hum, if

not heard in the speaker, or a headset connected across the cutting head, is due to turntable rumble or vibration. Inspect the drive mechanism, and make sure that all moving parts are oiled that should be.

Flutter: A recording stylus that is "digging in" the record material will often cause a flutter. This distorts all tone quality to the extent that some part of the electrical equipment might be suspected. If it is due to digging-in, the record will have the common shadows or herringbone pattern across its surface. The stylus vertical angle should be as shown in the previous article. If the front face of the stylus is not flat, remember that the cutting surface is the point of importance, not the shank of the stylus. If the cutting face has a semi-circular cut-out, the stylus should be tipped forward in order to compensate for the discrepancy.

Acoustic Howl: Some recorders develop an acoustic howl when the cutting head and loudspeaker are operated simultaneously (with the speaker functioning as a monitor). It is best to check this in the reproducing position, placing the pickup on the turntable, with turntable stationary, and increasing the gain to full output. When the cabinet is tapped gently, no howl should result; if it does, the recorder will never make an acceptable record until the mechanical feedback is eliminated.

Distortion: In the case of distortion, first go over the audio equipment in the usual manner. If it is found to be okay, check the stylus. Improper stylus adjustment or a defective stylus will create distortion even without creating high surface noise. Examine the recording head only after all other apparatus is found to be in perfect order.

(Turn to page 25)

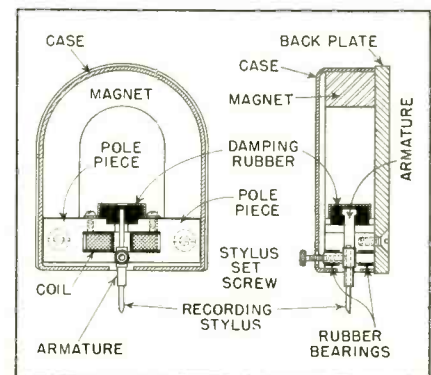

Fig. 3. General details of a magnetic cutting head. Recent models use less rubber for damping, or no rubber at all.

HELP STANDARDIZE

DRY-CELL TYPES

WHEN 1.4-volt tubes were first introduced, they made possible a portable radio designed for popular appeal and moderate price. At that time the radio manufacturers were almost unanimously decided on using two 45-volt "B" batteries, each containing thirty size-B cells, and a 1½-volt "A" battery containing four size-F cells.

These early portables usually had a 250-ma "A" drain and 9-ma "B" drain. At these figures, it was found that the "A" battery would last approximately 190 hours. This required using two "A" batteries to balance out the life of one set of "B" batteries. However, even this plan was not ideal, since it required operating the set with a slightly low-voltage "A" battery (just before it reached the point where it should be replaced), which tended to further shorten the life of the "B" battery. To correct this, an "A" unit, consisting of six F cells, and, for heavier drain sets, a unit containing eight F cells, were designed. These batteries were adopted by some set manufacturers who designed their new models with a battery compartment large enough to accommodate these heavier batteries.

PREFERRED DRY-CELL BATTERY TYPES

Type	Dimensions	Ray-O-Vac	Burgess	Eveready	General	Usa Lite	Winchester	Philco
1½v. Std. "A".....	2½×2½×4 1/8	P94A	4F	742	4F1	634	4816	P94
1½v. H.D. "A".....	3 1/8×2 3/4×4 1/2	P96A	6F	743	6F1	637	4814
1½v. Super H.D. "A".....	3 1/8×2 3/4×5 1/8	P98A	8F	741	8F1	635	4819
6v. Std. "A".....	2 5/8×2 3/8×4 1/8	P694A	F4PI	..	4F4	639
6v. H.D. "A".....	3 3/8×2 1/8×5 1/2	P698A	2F4	718	8F4	638	4817
45v. Std. "B".....	2 1/2×4 1/8×5 1/4	P5303	B30	762	V30B	624	6218	P305

When "three-way" sets were introduced, 6-volt "A" batteries, containing either four or eight F cells, were made available. For set manufacturers endeavoring to simplify battery replacement by designing sets to operate from a single combination pack containing both the "A" and "B" units tapped from a single socket, the normal drains as outlined in the second paragraph of this article should have been borne in mind, and a unit containing six F cells in the "A" section, and sixty B cells in the "B" section could have been easily adopted in a pack weighing approximately eight pounds. For lighter sets, an "A" unit of four F cells with a "B" unit of sixty B cells would also balance out nicely in

★ THE SIX TYPES LISTED BELOW ARE STANDARD FOR MOST RECEIVERS AND HAVE THE LARGEST TURNOVER. PRIVATE BRAND TYPES MAY GO DEAD ON YOUR SHELVES.

service, and would weigh approximately five pounds.

It should be clearly understood that these six batteries with the two proposed combination packs, mentioned above, were all the types necessary to operate any receiver designed around the new 1.4-volt tubes. But—here the picture changes.

PRIVATE BRANDS

Some set manufacturers, trying to control the battery replacement business, since they were doing a jobber business on private brand batteries, had their battery supplier design new units of a special shape or voltage and use newly designed socket connections, together with new set hookups. This was evidently planned while suffering from the illusion that no other battery manufacturer could obtain a sample and make a duplicate.

As a result of such sharp practices on the part of a few set manufacturers, all battery manufacturers today are making special types of "A" and "B" batteries,

THE NEW CROP

This situation is being further complicated today by the same manufacturers who, not content with last year's sets, with their corresponding types of batteries, will soon introduce 1941 models with another bevy of new batteries. These manufacturers are doing more today to hurt the rising popularity and sale of portable radios than most dealers realize. The unsuspecting consumer, after having difficulty in obtaining replacement batteries, will be discouraged with portable radios in general, and even a few dissatisfied users can do a lot of harm, in spite of the sounder business principles of the reliable manufacturers.

Notable exceptions to the sharp practices as outlined above are Air King, DeWald, Emerson, Espey, Fada, General Electric, Knight, Lafayette, Mission Bell, Packard-Bell, Pilot, RCA, Remler, Sentinel, Sonora, Sparton, Stewart-Warner, Trav-Ler, Troy, Warwick, Westinghouse, and a few others. These companies have stuck to the accompanying preferred list of six batteries in most instances.

Dealers would do well in the future to stock only those sets which operate on these batteries. In doing so, they will be protecting their future replacement business by simplifying buying, reducing inventory and investment, speeding stock rotation, and relieving sales problems.

CORRECTION

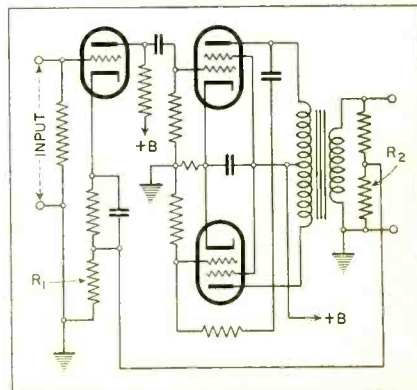

In Part II of the article "Practical Use of Inverse Feedback", the feedback resistors R1 and R2 in Fig. 5, page 25, were incorrectly marked. The proper designations are given above.

as well as combination packs designed for a few special receivers, and in some instances, for only one make and model of set. Special batteries, such as 4½-volt and 7½-volt "A", one-cell and two-cell "A"s, the standard 1½-volt "A" in a special shape, a 6-volt unit with a special three-hole socket, a heavy-duty 6-volt "A" in a special shape, 30- 51- 88½- and 90-volt "B"s, as well as special plug connections, were introduced and are required today to operate the sets that the unsuspecting dealers are selling. Hence, such dealers, when trying to do a satisfactory replacement business, must choose between a variety of at least fifteen "A" units, sixteen "B" units, and fifteen combination packs.

**MILES FROM PORT
YET SAFETY AT ARMS LENGTH!**

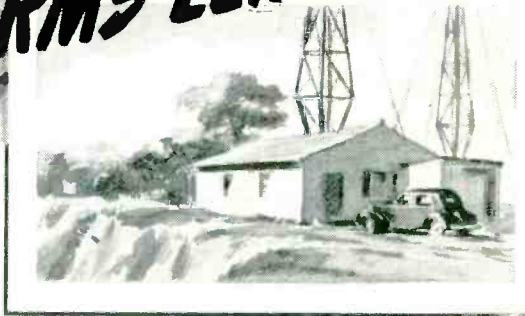

24 HOUR SHIP-TO-SHORE COMMUNICATIONS SERVICE PROVIDED BY GREAT LAKES COASTAL STATIONS WITH THE AID OF

RAYTHEON TUBES

The new marine radiotelephones make it almost as easy for a boat owner to "call up" his home, office or the Coast Guard as though he were on land. He merely picks up a telephone handset and talks! Stations like the Lake Bluff Coastal Radio Station on the western shore of Lake Michigan and the Loraine Station on Lake Erie handle the traffic . . . "hooking up" the boat by a land wire to any telephone in the world!

With transmitters and receivers on the air 24 hours a day, the station equipment takes a beating. It isn't any wonder that RAYTHEONS carry the burden.

RAYTHEONS were chosen because tube efficiency and dependability is important. Yet they are just "stock" tubes, such as are used by thousands of servicemen for replacement work . . . servicemen who know that the way to be the biggest service organization in town is to insist on quality parts. Yet RAYTHEONS cost *no more!*

Your Raytheon Distributor has an unusual tube deal for you. See him without delay.

NEWTON, MASS. • NEW YORK • CHICAGO
• SAN FRANCISCO • ATLANTA

WORLD'S LARGEST EXCLUSIVE RADIO TUBE MANUFACTURERS

Serviceman's Diary

By J. P. HOLLISTER

WEDNESDAY—Four calls already on the hook, so I shoved off early. Took the volume control replacement job at the Doc's house first, which is in the opposite direction from the other calls, and left word with Jerry to give me a ring there if he picked up any more calls in that neighborhood.

The Doc has a swell place, a big, brick house set well back from the street and surrounded by trees and hedges. His wife does a lot of entertaining, which is about the quickest way a doctor can build up a practice when he hasn't been established very long in the community, and the house is fixed up accordingly.

The basement is fitted up with a real bar, and there are small, round tables and metal chairs scattered around the room so that those who do not want to drink perpendicularly, or become no longer able to do so after a couple of his high-power concoctions, can sit at the tables and pass out in comfort.

The Doc laid out the place himself and overlooked nothing. Near the bar is a toilet, and inside hangs an enormous pencil and drawing paper. The pencil is anchored to the door by a heavy string, just long enough so the pencil may be used on any portion of the drawing paper and nowhere else. Thus those who habitually become poetically or artistically inclined in such surroundings have the opportunity to express themselves without defacing the walls.

The basement set is a Radiola 48. About every year or so it needs a new volume control, in addition to a cleaning up of the gang condenser shield and wiping contacts. I never pull the chassis for a volume control replacement on this job. You know the model—the chassis is mounted vertically in the cabinet with

the speaker below. It's a nuisance to pull the chassis, since the speaker wires have to be unsoldered before the speaker can be taken out, and the chassis itself is awkward to handle. For me, the easiest way out is to face the cabinet against the wall, remove the chassis bolts and tip the chassis back into my lap, letting the bottom end of the chassis rest on its usual supports inside the cabinet. Then, while sitting more or less comfortably in a chair, I can take out the old control and transfer its leads, one by one to avoid getting balled up, to the new control.

I had just about finished the job when the Doc's wife called down that I was wanted on the phone. It was Jerry.

"Listen!" he said, "I just got a rush call from Mrs. Brown, right around the corner from where you are. The washing-machine just went haywire and she's all upset over it. The laundress comes only once a week and she is standing around, doing nothing, since the machine went on the blink—"

"Wait a minute," I protested. "I'm a radioman, not a washer-woman. I don't know anything about washing machines."

"Take it easy," he replied soothingly, "it doesn't sound like a hard job. It worked all right for about a half-hour this morning, then it stopped suddenly and now it blows fuses as fast as she puts 'em in. Remember, last week you put a new belt on her vacuum cleaner, so she thinks you can fix anything. She's a good customer, so see if you can help her out."

"OK," I told him. "Any suggestions?"

"Yes," he came back. "Don't forget that it's a washing machine, not a radio. Don't tell her you'll have to check the tubes; it's got tubes but they won't fit your tube-checker. Don't ask her if it

fades; if they have any fading trouble, it's in the colored clothes and not in the machine. Don't try to check for waveform distortion; you'll get all splashed with soap-suds. Don't—"

"Good-bye!" I yelled, and slammed down the receiver. What *can* you do with a guy like him?

I finished the Doc's job and collected. They always pay cash, which is a gentle hint that he doesn't want any of us to run up bills on him when we need *his* services.

Mrs. Brown lives about two blocks from the Doc, in a small, white house. She has a large family so I imagine that wash-day means lots of work for her. She gets upset very easily. When Mr. Brown got a demonstration of one of our new f-m, a-m combination receivers, he told Jerry she thought morning programs were dull and wanted him to wait until we got f-m, p-m sets so they could listen in the evenings.

She saw me coming and had the front door open before I could ring. She repeated the story which Jerry had told me over the phone and led me down to the basement. I found the fuse box and put in a fresh 10-amp fuse.

The laundress had the top off the machine and I looked down into a sea of bluish water and white linen. I had never worked on one of these things before and felt rather lost. They showed me where the power switch was so I turned it on. A groaning hum from the motor was the only result and I turned off the power instantly, before the fuse had a chance to blow.

The motor was under the machine and was coupled to a gear box by a belt. I tried to pull the belt and make

(Turn to page 32)

HORACE—

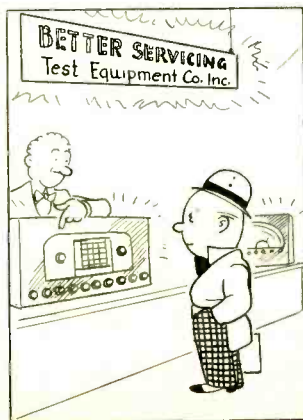

SHOW PREVIEW **2 OF 22** NEW MODELS



\$29⁹⁵

Terms: \$4.00 cash
and 8 monthly
payments of \$3.63

**FREE TUBE SETTING SERVICE
FOR ONE YEAR**

IN producing Model 589 there has been no compromise in the circuit design or materials. The same manufacturing methods, careful inspection and accurate calibration are incorporated in this instrument as in all other SUPREME testers. It will pay you to investigate and see this tester before you buy. Its price is the lowest at which a GOOD tube tester can be built.

MODEL 589 TUBE AND BATTERY tester has a completely modernized circuit. The tube test sockets are not wired directly to the circuit, but, instead, pass through the patented SUPREME Double Floating Filament Return Selector system which automatically re-connects all tube elements to any possible tube base arrangement. Due to the fact that any or all elements of each socket can be rotated to any desired position, only one socket of each type is necessary. Tests every type of tube from 1.4 volts to full line voltage at its correct anode potential under proper load. Tests separate sections in multi-purpose tubes. Checks all leakages, shorts, open elements and filament continuity with a neon lamp. A circuit insert is provided for checking noise, leakage, loose and bad connections. The battery testing circuit of the Model 589 provides the proper load at which each battery is to operate, plainly marked on the panel, for all 1.5, 4.5, 6.0, 45 and 90 volt



Illustrated above is the Model 589 in a counter type metal case. This model is available with option of 7" or 9" illuminated meters. Has two neon lamps for sensitive or super-sensitive tests.

portable radio types. The condition of the battery is indicated on an English readings scale. This is the fastest and easiest tester to operate. Just "follow the arrows"—you can't go wrong. Roller type tube chart with brass geared mechanism lists tubes in logical numerical order. Each tester carries a one year free tube setting service. SUPREME engineering and construction PLUS the best materials the market affords, make the 589 your biggest dollar value. You will be proud to own this instrument.

MODEL 599 TUBE AND SET TESTER is very similar in appearance to the Model 589, and includes all the features and advantages of this instrument. In addition, it provides the following ranges:

0.2 to 1500 D.C. Volts—5 carefully selected ranges—0/6/15/150/600/1500 volts. 1000 ohms per volt standard sensitivity.
0.2 to 600 A.C. Volts—4 A.C. ranges—0/6/15/150/600 volts. Rectifier guaranteed with instrument and fully protected from overload damages.
0.2 M.A. to 600 M.A.—3 direct current ranges 0/6/60/600 allow measurement of screen, plate, "B" supply and D.C. filament loads.
0.2 to 600 Output Volts—0/6/15/150/600—ideal for alignment. No button to hold down—no external condenser necessary.
0.1 ohm to 20 megohms—4 ranges 0/200/20,000 ohms, 0/2/20 megohms. A low range at high current with 3.5 ohms center scale.

Electrostatic — Electrolytic Leakage Test— Sensitive calibrated 20 megohm range provides excellent leakage test of paper and electrolytic condensers. Just as the 589 is your best value in a tube and battery tester, the 599 is your best value in a combination tube tester, battery tester and set tester. Remember, you have all the features of the 589 PLUS a complete AC, DC volt, ohm, megohm, milliammeter, at a cost of only 47c per range.

Dealer Net Cash Price

\$39.50

Terms: \$4.50 cash;
9 payments of \$4.33.



Metal cabinets as illustrated for the Model 589 at left and 599 above are identical—can be used either in a horizontal position or vertical position by merely reversing the instrument panel. Write for information.

SUPREME

SUPREME INSTRUMENTS CORP.
GREENWOOD, MISSISSIPPI, U. S. A.

SEE US AT THE PARTS SHOW, BOOTHS 821 AND 823

TELEVOX

JOBBERS MAKE MONEY

and so can you!

Mr. Jobber!

Here is the "Bank's Plan" which is clicking for every Jobber who has tried it. These Jobbers are making **TELEVOX Intercomm** the nucleus of their sound departments. They simply put a few *Demonstrators* at a time into their territories through their own salesmen with the cooperation of their service and sound men customers who bring in leads. These *demonstration* units easily sell themselves—and lead to additional recommendation sales. Everybody profits!

TELEVOX Intercomm systems are a staple item with a better than average net profit. They are easily demonstrated and sold because their advantages are so obvious to the user. Models do not change or become obsolete. Only a small initial investment can be turned over many times a year. There are no seasonal peaks or dips for intercomm sales.



BANK'S TELEVOX Systems assure you of high quality priced low enough to attract even the "price" buyers—at a good profit. Bank's Manufacturing Company is the oldest company in this field and is internationally known for its high standard of quality.



BANK'S MANUFACTURING COMPANY
5019-21 N. Winthrop Avenue, Chicago, Illinois, U. S. A.
Licensed Under BANK Patent No. 1,922,115

Make Intercomm a profitable part of your business

In every locality, large and small, there are logical customers for intercommunication equipment. Everywhere you turn, you will find factories, offices, hospitals, clubs, schools, depots, boats, restaurants, etc., that will buy intercomm systems once their practical use is demonstrated to them. Over 50,000 intercomm installations were sold last year by aggressive Jobbers and intercomm salesmen. Sales so far this year are ahead of last year. Are you getting your share?

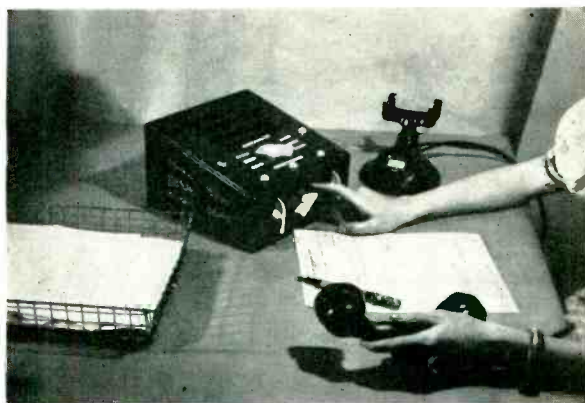

Mr. Service and Sound Man!

It's no longer necessary to grope for profits. Intercomm has proven itself a real source of income—from sales, installation fees and maintenance. All around you are thousands of potential customers—a ready market that's waiting to buy. **DEMONSTRATE** Televox Intercomm—show its advantages. It's so easy. Replace inoperative systems, too. Or—get demonstration leads for your Jobber. **YOUR JOBBER** will work with you on the demonstration and the sale. Share in the profit. And get installation and maintenance fees besides.

**The "Bank's Plan" Works!
Send for Details Today.**

**Televox prices begin at \$39.95
subject to regular trade discounts.**

TECHNICAL SERVICE PORTFOLIO

SECTION II

TEST-OSCILLATOR APPLICATIONS

IN the majority of service shops, the test oscillator serves as a signal source for alignment purposes and nothing more. Not that experienced servicemen are unaware that it has other applications, but principally because other routine test methods usually are more rapid and convenient to apply for the more common run of receiver troubles. But for the more obscure and time-consuming problems which often arise in servicing, the test oscillator can be used in an unconventional manner to localize the trouble in less time than by hit-or-miss methods.

SIGNAL INJECTION

One fundamental application of the test oscillator in trouble shooting which deserves to be more widely used is in stage-by-stage elimination tests by the oscillator-output meter method. This is also called signal injection or signal substitution. The procedure is to inject an audio signal into the grid circuit of the output stage and note or measure the resulting output across the speaker voice coil. If this stage functions normally, it is eliminated as a possible cause of the trouble. The signal is then fed to the preceding a-f stage in the same manner and a satisfactory response from the speaker thus eliminates both a-f stages. Tests of the i-f amplifier and r-f and converter stages then follow in the same order, feeding a modulated i-f or r-f signal at the frequency to which the circuit under test is tuned and noting the audio response at the speaker.

The purpose of this test is to localize the trouble to one particular stage so the search for the defective component is narrowed down to routine tests of but a few parts rather than a catch-as-catch-can test of a large number of components which cannot affect the operation of the particular stage in which the trouble is

present. Naturally, there are many components in power-supply circuits which are common to all stages, so the usual procedure is to check the power-supply voltages first, as well as the tubes, to eliminate the more obvious possible causes of defective performance.

For example, let us assume that the skeleton schematic, Fig. 1, represents the circuit of a superheterodyne receiver which we are to test by this method. A preliminary test has shown that the tubes and voltages are normal but the set is inoperative.

For our tests of the a-f system we shall require an audio signal. This is usually obtainable from the r-f test oscillator, since most present-day test oscillators have provision for using the 400-cycle modulating voltage externally. Usually a blocking condenser is provided within the test oscillator; if not, a 0.1-mfd condenser should be employed between the "high" side and the circuit under test when the circuit does not return directly to ground. This precaution is necessary to avoid shorting the grid bias.

The a-f signal is fed first to point 1,

the output tube grid. If no 400-cycle response is heard in the speaker, then the trouble is immediately localized in some component which affects the operation of the last a-f stage, or in the speaker itself. If a response is obtained, then the signal is fed to point 2, the control grid of the first a-f tube. No response at this point localizes the trouble between the first a-f and output stages.

R-F, I-F TESTS

Assuming that the audio signal is reproduced when the signal is fed to each of the first two test points, the i-f amplifier and detector should next be checked. The test leads are accordingly connected to the r-f output terminals of the test oscillator and the instrument is adjusted to produce a modulated i-f signal. This signal is then fed through a blocking condenser to point 3. No response in the speaker localizes the trouble between the last i-f and first a-f stages. If a response is obtained, the signal is similarly fed to the converter grid, point 4. Normally, the signal reaching the converter grid is at the broadcast frequency to which the receiver is tuned, but by feeding an i-f sig-

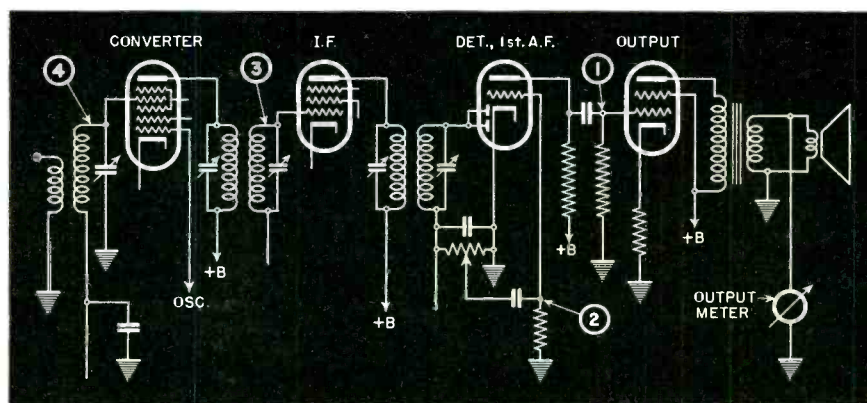

Fig. 1. Skeleton schematic of superheat showing signal-injection points for testing with signal generator and output meter.

nal first to this point we obtain a check on the performance of the first i-f transformer and the operation of the converter tube independently of its functions as an oscillator and mixer.

The next step is to test the operation of the converter as an oscillator and mixer. This is done by retuning the test oscillator to produce a modulated r-f signal at the frequency to which the receiver is tuned. The signal is fed to point 4 as before. If no response results, then there is some fault in the oscillator circuit of the receiver.

If a response is obtained at all test points so far checked, then the trouble is localized between the antenna and the input signal grid of the converter tube and no further signal injection is required.

This, then, is the general procedure for stage-by-stage elimination tests. Note that in all these tests the grid connections in the receiver remain undisturbed. It is unnecessary to remove grid leads when shunting the test oscillator leads across either tuned or untuned circuits since the output impedance of the test oscillator attenuator is very low in comparison with the tuned or untuned circuit impedance. The sole exception is when an i-f signal is being fed to the input circuit of the converter tube. With some test oscillators, when the receiver is tuned for short-wave reception and the i.f. is of the order of 450 kc, the input circuit impedance at 450 kc will be very low. However, if the band switch on the receiver is set for broadcast reception and the receiver is tuned to the low-frequency end of the band, the tuned circuit impedance will be sufficiently high so that the signal output of the test oscillator is not appreciably reduced. This does not interfere with the usefulness of the test, since if the receiver operates on the broadcast band but not on a short-wave band, the fault is automatically localized in the r-f and converter circuits.

So far we have considered the localiza-

tion of faults in an inoperative receiver. The same procedure is followed for localizing noise with the exception that the stage preceding the one under test may have to be rendered inoperative to prevent the noise from riding through. Checking for distortion is also done similarly, using an oscillograph as an output indicator when the distortion is too slight to be detected on a 400-cycle note. Alternatively, the test oscillator may be modulated with a phonograph record since distortion on music or speech is more apparent than on single-frequency modulation.

One point in connection with distortion checking in audio circuits should be observed; when an audio signal is fed to the first a-f grid following a diode detector, the diode circuit should be opened. Otherwise the diode will draw current on the positive half of the applied audio signal wave and cause distortion which is not produced when a modulated r-f or i-f signal has been rectified and passed on to the a-f amplifier. Alternatively, the first a-f circuit may be checked by feeding the modulated i-f signal to the last i-f grid.

CHECKING WEAK RECEIVERS

If the receiver output is subnormal, it is apparent that the gain in one or more stages must likewise be below normal, or the speaker itself defective. This means that some method of determining stage gain must be available. Signal-tracing instruments, as described in Section I of the Portfolio, represent the most efficient and accurate means of making such tests in service procedure, but if no such instrument is at hand a calibrated test oscillator may be used.

In audio stages, the problem of gain measurement is not particularly difficult. The normal output of an average modern receiver is approximately 1/2 watt when an audio signal of .05 to 0.1 volt is applied across the volume control. This assumes that the usual stage lineup of a

TABLE I

AVERAGE GAIN-PER-STAGE VALUES

The gain-per-stage figures listed below are average and are based on the assumption that the receiver avc system is not operating. The avc action will reduce the r-f, mixer and i-f stage gains. For comparison purposes, a weak signal should be used or the avc action temporarily shorted out.

In the a-f section, for resistance-coupled amplifiers, the lower gain figures represent average gains for a-c/d-c receivers while the higher gains apply to a-c operated receivers.

R-F SECTION	
Antenna to grid of first tube	2 to 10
Antenna to grid of first tube (auto-radios)	10 to 50
R-f amplifier, superheterodynes	10 to 40
R-f amplifier, t-r-f receivers	50 to 100
MIXER SECTION:	
Converter grid to i-f grid (1-stage i-f amp.)	30 to 60
Converter grid to i-f grid (2-stage i-f amp.)	5 to 20
I-F SECTION:	
I-F Stage (1-stage amp.)	40 to 150
I-F Stage (2-stage amp.)	5 to 20
BIASED DETECTOR:	
PENTODES (Types 57, 6C6, 6I7)	
A 1.0 volt rms signal (modulated 20%) at the grid will produce approximately 10 volts rms of a-f at the plate. Higher modulation percentages will produce correspondingly higher a-f voltages. Thus, 40% modulation will produce 20 volts rms of a-f at the plate.	
A-F SECTION:	
MEDIUM-MU TRIODES, RESISTANCE-COUPLED:	
Type 6N7, 6C8, (each section)	20 to 25
HIGH-MU TRIODES, RESISTANCE-COUPLED:	
Type 75, 2A6, 6F5, 6SQ7	40 to 55
PENTODES:	
Type 2B7, 6B7, 6B8	50 to 80
Type 6F6, 2A5, 47, 6V6 6K6, (grid-to-plate gain)	8 to 20
TRIODE OUTPUT TUBES:	
Type 2A3, 45, 71A, 6A5G	2 to 5

This table appears in *Servicing By Signal Tracing*, by John F. Rider, and is reproduced by permission of the author.

single high-gain resistance-coupled a-f stage is followed by a single pentode output stage.

A simple attenuator for the 400-cycle output of a test oscillator which will provide the required a-f signal voltage for a quick overall check of an a-f amplifier is shown in Fig. 2. This attenuator, preferably shielded, is to be connected across the a-f output of the test oscillator. If some means of controlling the output level of the 400-cycle tone is available within the test oscillator, R1 may be omitted. The required resistance of R1 depends on the a-f output voltage of the test oscillator.

The output signal voltage is checked at 10 volts, using the 100-volt scale of a 1000-ohms-per-volt copper-oxide type a-c meter to avoid loading the circuit too much. The test output levels of .05 or 0.1 volt may then be taken across R4, or R3 and R4 in series, as shown.

With this arrangement, a test of the a-f gain may be quickly made by connecting the output of the attenuator across the receiver volume control and measuring the signal voltage developed across the speaker voice coil.

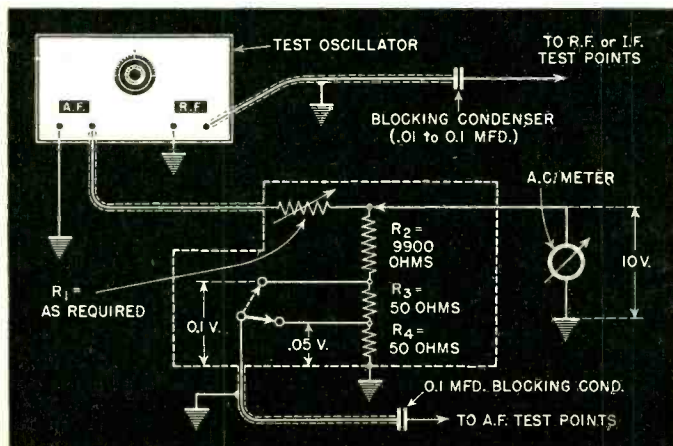

Fig. 2. Circuit of simple attenuator for the output of a test oscillator which provides means of measuring gain.

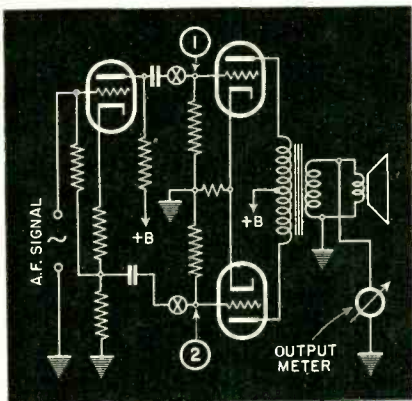

Fig. 3. Single-tube phase-inverter circuit, easily checked with test oscillator and output meter.

The audio signal voltage across the speaker voice coil required to produce the desired wattage output may be determined from the following formula—

$$E = \sqrt{RW}$$

in which E is the signal voltage across the voice coil, R is the voice coil impedance at 400 cycles and W is the desired watts output. For a 3.5-ohm voice coil, $\frac{1}{2}$ watt output is obtained when E equals the square root of $(3.5 \times \frac{1}{2})$ or about 1.3 volts.

Precise measurements are not necessary in trouble shooting, since the gain in any amplifying stage normally varies over a rather wide range, due to varying tube characteristics, tolerances of components and line-voltage variations. Such variations may cause the rated gain to vary 25 to 50 percent above or below the specified values. However, this does not mean that accuracy is not desirable in the test apparatus; the fewer variables which are present in any test, the more reliable and the more quickly the test may be made.

In checking r-f and i-f circuits for gain, considerable variation in signal level and modulation percentage occurs in simple test oscillators. Therefore, only rough measurements in such circuits are possible unless a precision signal generator, accurately calibrated in microvolts and supplying a signal of known percentage modulation is employed. When such equipment is available, receiver sensitivity may be measured and the signal gain in any stage may be determined.

To measure the gain in an i-f stage, the signal is fed to the last i-f grid as has been previously described and the microvolts input, modulated at 400 cycles, which is required to produce a given output meter reading, is noted. The signal generator connections are then transferred to the i-f grid immediately preceding and the microvolts input, with the

same degree of modulation, which is required to produce the same output meter reading, is noted. The ratio of the first input level in microvolts to that of the second input level determines the gain. For example, in a *Motorola 5A* receiver, a 4500-microvolt signal at 455 kc, modulated 30% at 400 cycles, should normally produce 0.45 volt across the speaker voice coil when this signal is injected, through an 0.1-mfd condenser, to the last i-f grid (corresponding to point 3 in Fig. 1). The same audio voltage across the speaker voice coil is also normally produced when a 75-microvolt signal is injected at the preceding tube grid (corresponding to point 4 in Fig 1). The stage gain is then 4500/75 or 60. Average Gain-Per-Stage Values are given in Table I.

If no signal generator with an attenuator reliably calibrated in microvolts is available, approximate results may be obtained by calibrating the test oscillator attenuator at various frequencies in the i-f and broadcast-band ranges. For example, if the points at which the attenuator control is set when a signal fed to i-f and r-f grids in a given receiver in normal operating condition to produce a given output are noted on the schematic, then when another receiver of the same type comes in for service, some guidance as to the proper stage gain which should be expected will be available.

In trouble shooting in r-f and i-f stages by this method, it is a good idea to realign each stage as the signal is being injected. Then, when the trouble is located and corrected, there will be a minimum of additional work to do before returning the receiver to the customer. The actual process of aligning will often reveal many troubles. For instance, a shorted trimmer across an r-f or i-f transformer will often show up when the adjusting screw is turned. And, in the case of i-f transformers which have become affected by moisture, broadness of tuning when aligning will show that the transformer is not operating at normal efficiency. In some cases, this effect may also be caused by an open bypass condenser in the primary or secondary return circuits.

CHECKING FOR MODULATION HUM

This annoying trouble is often difficult to localize by ordinary test methods. With the test oscillator, the job is simplified. The first test is to make certain that there is no excessive hum in the power-supply circuit. If so, this will be evidenced by a high hum output from the a-f amplifier when the a-f volume control is set at minimum. If the hum level under such conditions is normal and the hum is apparent only when the receiver is tuned to a broadcast station during periods when the broadcast signal is not

modulated, then an *unmodulated* signal from the test oscillator may be fed to the r-f and i-f stages of the receiver until a point is reached where the hum first becomes evident. Occasionally this trouble will be caused by high-resistance shorts in tubes which are not caught by the tube checker. Other possible causes are misplaced leads, poor filtration of r-f, oscillator or i-f plate- or screen-supply voltages, rectification due to overload caused by avc trouble, and defective diodes.

Often modulation hum will not be apparent when the receiver is on the test bench, due to the inability of the speaker to reproduce hum when no baffle is used. However, the presence of hum will be indicated on an output meter or by noting the vibration of the cone with the fingers.

CHECKING PHASE-INVERTER CIRCUITS

Often troubles in phase-inverter circuits pass unnoticed through the service shop, largely because proper means for checking such circuits are not available. In actual service, too, the customer may not notice the trouble unless the receiver is operated at relatively high volume.

The operation of such circuits is quite simply checked with a modulated r-f signal introduced ahead of the detector, or with an a-f signal fed to the input of the a-f amplifier. Signal voltages which are equal in magnitude but opposite in phase should appear at each push-pull input grid. These voltages may be directly measured with a tube voltmeter or by means of a cathode-ray oscillograph, but the loading effect of the usual copper-oxide type a-c meter is ordinarily too great to permit direct measurement of such signal voltages in grid circuits.

(Turn to page 18)

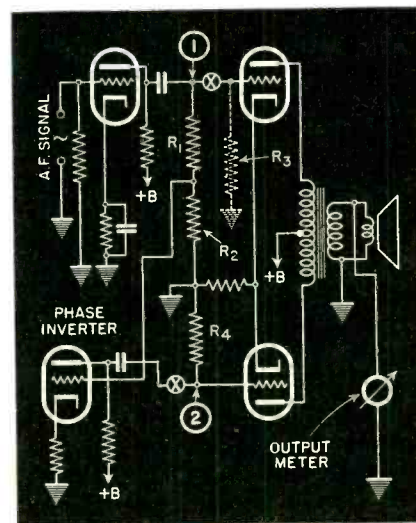
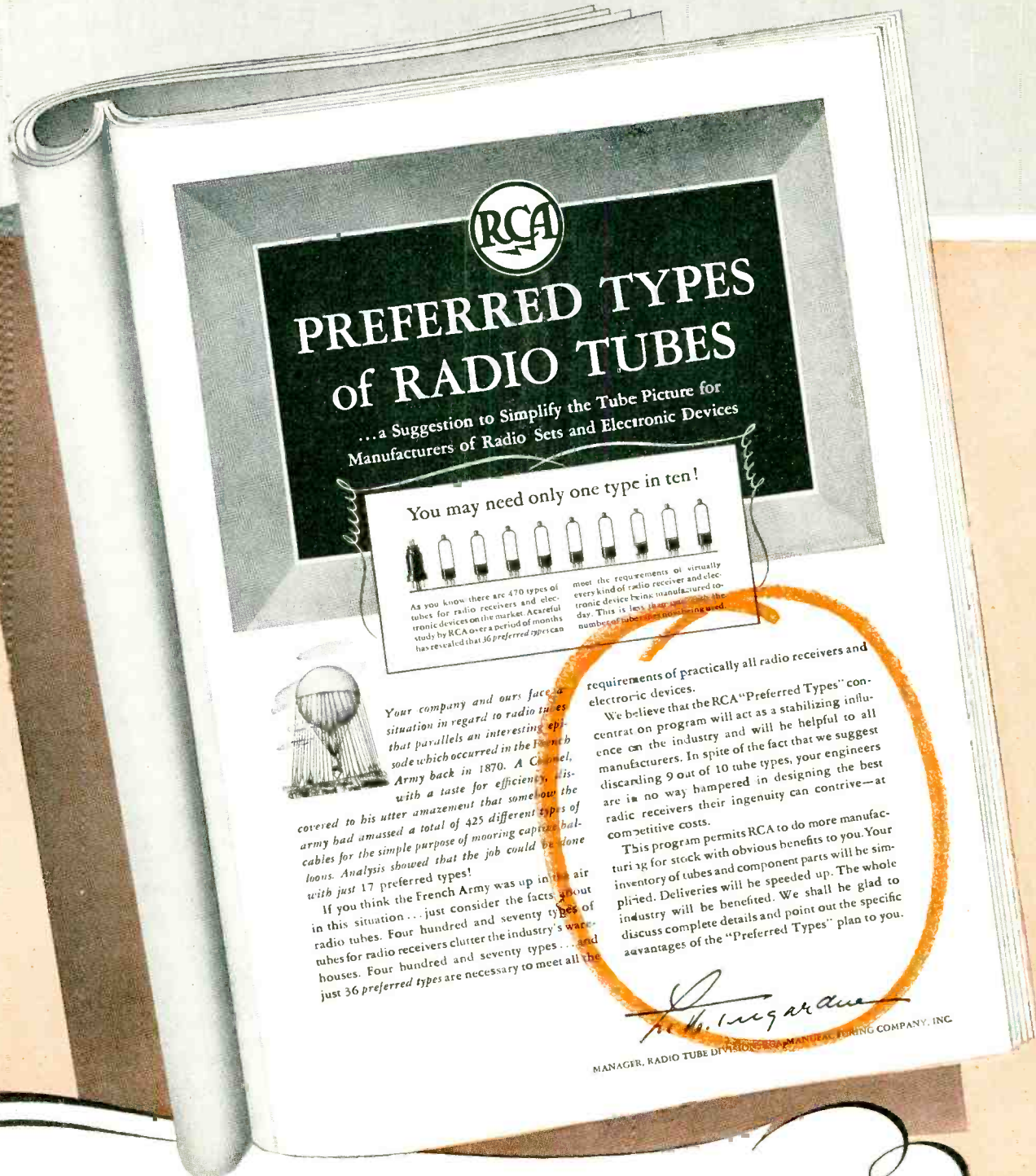

Fig. 4. Circuit with additional tube for phase inversion. This may also be checked with test oscillator and output meter.

PROMISE... and PERFORMANCE!...



RCA
PREFERRED TYPES
OF RADIO TUBES

... a Suggestion to Simplify the Tube Picture for
 Manufacturers of Radio Sets and Electronic Devices

You may need only one type in ten!



As you know there are 470 types of tubes for radio receivers and electronic devices on the market. A careful study by RCA over a period of months has revealed that 36 preferred types can meet the requirements of virtually every kind of radio receiver and electronic device being manufactured today. This is less than one percent the number of tubes that are being used.



Your company and ours face a situation in regard to radio tubes that parallels an interesting episode which occurred in the French Army back in 1870. A Colonel, with a taste for efficiency, was covered to his utter amazement that some of the army had amassed a total of 425 different types of cables for the simple purpose of mooring captive balloons. Analysis showed that the job could be done with just 17 preferred types!

If you think the French Army was up in the air in this situation... just consider the facts about radio tubes. Four hundred and seventy types of tubes for radio receivers clutter the industry's warehouses. Four hundred and seventy types... and just 36 preferred types are necessary to meet all the

requirements of practically all radio receivers and electronic devices.

We believe that the RCA "Preferred Types" concentration program will act as a stabilizing influence on the industry and will be helpful to all manufacturers. In spite of the fact that we suggest discarding 9 out of 10 tube types, your engineers are in no way hampered in designing the best radio receivers their ingenuity can contrive—at competitive costs.

This program permits RCA to do more manufacturing for stock with obvious benefits to you. Your inventory of tubes and component parts will be simplified. Deliveries will be speeded up. The whole industry will be benefited. We shall be glad to discuss complete details and point out the specific advantages of the "Preferred Types" plan to you.

J. Edgar Hoover

MANAGER, RADIO TUBE DIVISION, ELECTRONIC TUBING COMPANY, INC.

"THE WHOLE INDUSTRY will be benefited," predicted this original announcement of the RCA Preferred Type Tubes Program, which appeared in December, 1939.

Only 6 months later, sixteen manufacturers who have adopted the program to their production, publicly endorse it... lend to its advancement the weight of their names... precisely because they have benefited from this program.

Six months... Already, inventories are simplified. Already, warehousing costs are lowered. Already deliveries are quicker. And more production has meant less costly production of better, more uniform tubes!

In the months to come, the Preferred Type Tubes Program will see still further advances—still further benefits to manufacturer, distributor, dealer and consumer alike.



16

LEADING SET MANUFACTURERS

Have Now Endorsed and Adopted RCA Preferred Type Tubes Program

JUST six short months ago—as a decade ended and a new decade began—came the significant and timely announcement of the most far-reaching policy in the history of the tube industry: the RCA Preferred Type Tubes concentration program.

That announcement, here reprinted, pointed a way out of the confusion that for ten years had increasingly hampered the industry.

The promises of that program, and its predictions, are *working* in practice—to the betterment of the entire industry!

To these sixteen manufacturers who have so helpfully endorsed this program, adopted it, and cooperated in its advancement, we wish publicly to acknowledge our sincerest appreciation and thanks.

Over 335 million RCA Radio Tubes have been purchased by radio users.

Andrea



F. A. D. Andrea, President
Andrea Radio Corporation
Woodside, L. I., N. Y.

Continental



J. H. Clippinger, Vice-Pres.
Continental Radio and
Television Corporation
Chicago, Ill.

Detrola



John J. Ross, President
Detrola Corporation
Detroit, Michigan

DeWald



David Wald, President
DeWald Radio Mfg. Co.
New York, N. Y.

Emerson



Ben Abrams, President
Emerson Radio and
Phonograph Corporation
New York, N. Y.

FADA Radio



J. M. Marks, President
Fada Radio and Electric Co.
Long Island City, N. Y.

Farnsworth



E. A. Nicholas, President
Farnsworth Television and
Radio Corporation
Fort Wayne, Indiana

GAROD



Max Weintraub, President
Garod Radio Corporation
New York, N. Y.

Gilfillan



Gilfillan Brothers Inc.
S. W. Gilfillan, President
Los Angeles, California

Hallcrafters



W. J. Halligan, President
Hallcrafters, Inc.
Chicago, Illinois

PACKARD-BELL



Herbert Bell, President
Packard-Bell Co.
Los Angeles, California

Pilot



I. Goldberg, President
Pilot Radio Corporation
Long Island City, N. Y.

Sentinel



E. Alschuler, President
Sentinel Radio Corporation
Chicago, Illinois

Sonora



Joseph Gerl, President
Sonora Radio and Television
Corporation
Chicago, Illinois

Stromberg-Carlson

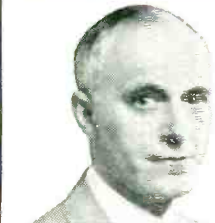

Fred N. Anibal, Radio Sales
Mgr., Stromberg-Carlson
Telephone Mfg. Co.
Rochester, N. Y.

WURLITZER



Ray C. Haimbaugh, Chief Eng.
Rudolph Wurlitzer Co.
North Tonawanda, N. Y.

Preferred Type Tubes

RCA Manufacturing Co., Inc.
Camden, N. J. • A Service of the
Radio Corporation of America

However, if none of this equipment is available, alternative methods of making these tests are possible, using only a test oscillator and any suitable type of output meter.

There are quite a number of variations of phase-inverter circuits, but the two shown in Figs. 3 and 4 will serve to illustrate how any such type of circuit may be checked.

Since any type of output meter may be connected across a low-resistance voice coil, the meter is shown connected at this point. Now, in operation, each of the push-pull output tubes should make the same contribution to the output signal if the phase inverter is operating properly. Accordingly, if an a-f signal is applied to the audio amplifier (or a modulated r-f signal to the receiver input) the a-f voltage indicated by the output meter should be the same when only one output tube is operating as it is when the other output tube is also functioning alone. It would seem, at first glance, that the simplest way to make a check would be to pull out one output tube and note the output meter reading, then replace that tube and remove the remaining output tube. The output readings should be the same.

This is, however, dangerous practice, due to the changing circuit loads. Better and safer results are obtained by first opening the coupling circuit between the grid of one output tube and the preceding plate, as shown at the cross within a circle in Fig. 3 adjacent to point 1. This leaves the a-f signal circuit open at the grid of the upper a-f output tube but the lower tube will still function. Note the output signal level under these conditions, then reconnect the upper tube grid and open the lower signal coupling circuit adjacent to point 2 in the same manner. The same output voltage should be indicated on the output meter when the phase inverter is operating perfectly. Actually, a variation of 10 percent in these voltages is satisfactory, since such variations are too inconsequential to affect reception.

In Fig. 4, the a-f signal fed to the

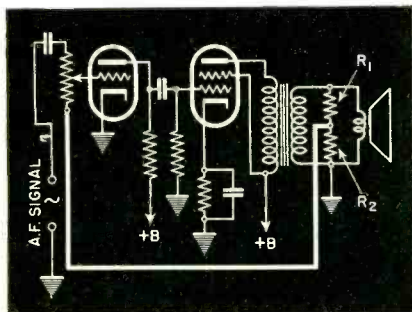

Fig. 5. Inverse feedback from voice coil to volume control. May be checked with modulated r-f signal to set input or a-f signal to first a-f grid.

phase-inverter tube is taken from a portion of the grid return circuit of the upper a-f output tube. Accordingly, the a-f coupling circuit cannot be opened in the manner described for the circuit shown in Fig. 3. Since the voltage divider composed of $R1$ and $R2$ must remain intact, the upper tube grid should be returned to ground, after opening its grid connection, through a resistor $R3$ which is temporarily used. The value of $R3$ should be of the order of $R4$. The signal output across the voice coil is then checked with each output tube inoperative in turn, just as was described for the circuit of Fig. 3.

CHECKING INVERSE FEEDBACK CIRCUITS

Negative feedback circuits are becoming more widely used this year and some consideration is therefore in order to provide simple tests of these circuits.

In operation we know that the effect of negative feedback is to reduce distortion at the cost of some decrease in gain. In fact, the greater the feedback the less the audio gain. Consequently, trouble in an inverse feedback network will normally have a pronounced effect on the gain of the a-f amplifier. In some circuits, the gain will be increased to a point where audio oscillation may result (if the feedback network is open-circuited), in others, the amplifier may become inoperative.

Two representative examples of inverse feedback networks, as used in modern receivers, are shown in Figs. 5 and 6. The circuit of Fig. 5 is commonly employed in many of the smaller midget models, while that shown in Fig. 6 is used in one of the new *Stromberg-Carlson* receivers.

The setup for test is similar to that employed in checking phase-inverter circuits. Either a modulated r-f signal may be fed to the receiver input terminals or an a-f signal may be applied to the input grid of the a-f amplifier.

In the circuit shown in Fig. 5, the volume control returns to ground through a voltage divider shunted across the speaker voice coil. The feedback voltage is developed across $R2$. The resistance of $R1$ is usually high in comparison with the voice coil resistance; hence, shorting $R2$ has little loading effect on the voice coil circuit. Accordingly, if we ground the junction of $R1$ and $R2$ (which can be accomplished quite simply by grounding the return terminal of the volume control) the feedback voltage will be shorted out.

Under this condition, then, there will be no feedback voltage fed into the a-f grid circuit. Therefore, the gain of the amplifier will increase and the output signal voltage across the speaker voice

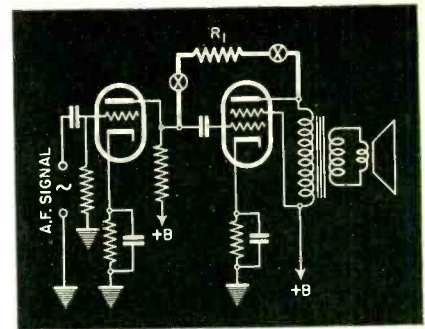

Fig. 6. Inverse feedback from plate to grid. Method of test similar to that for Fig. 5 circuit.

coil likewise will increase. The resulting increase in volume will be plainly audible without the use of an output meter to measure it.

If, due to an open circuit in $R1$ or $R2$, no feedback voltage is developed, then no increase in volume will result from this test. Thus, a quick and effective short-cut method for checking this type of inverse feedback circuit is provided.

In Fig. 6, the feedback voltage is fed into the plate circuit of the preceding a-f amplifier tube, and thence to the output tube grid, by means of $R1$. The method of test is similar to that described for the preceding circuit, with the exception that the feedback circuit must be opened, and not shorted, to remove the feedback voltage and thus increase the audio output.

SUMMARY

It may occur to the reader that many short-cuts, such as have been described, are equally applicable to other tests of receiver circuits. This is quite true, though such tests should not be of such nature that damage to the receiver may result. We refer particularly to the present practice, in some service shops, of pulling out output tubes to check for the "plunk" in the speaker when an inoperative receiver is being checked. When only a single output tube is employed, damage to the electrolytics often results from this practice. However, there is no harm in touching an audio grid to make sure the a-f amplifier is "live." In fact, when a receiver is inoperative or very weak, such quick tests are well worth while.

With the new single-ended tubes, however, many of these finger tests will become impractical. And often too much reliance is placed on such tests, with the result that sets which perform below normal are returned to the customer as repaired.

The proper use of better equipment will make for better servicing. And better servicing, in the long run, is more profitable.—J.H.P.

Circuit Court

F-M ALIGNMENT

FREQUENCY MODULATION is with us—and so are its troubles. But they aren't so hard to fix as you might imagine, to look at the diagrams of some of the combination jobs which also include all-wave amplitude modulation. And servicing can be made a lot easier.

Take a look at the diagram of the limiter stage of the *General Electric HM-136*, for instance, which is shown in Fig. 1A. This stage operates with low plate and screen voltages so it overloads easily—so easily, in fact, that any good healthy signal will flatten its nose against the input circuit, causing not only grid current, to flow through *R1*. Which is just exactly what is supposed to happen. Then there is a voltage drop, due to this current through *R1*, which can be used for avc purposes (though nobody needs avc in an f-m set) or to operate a tuning indicator (which is needed).

To align one of these i-f amplifiers, all you need is a frequency-modulated test oscillator with a sweep range of about 300 or 400 kc at 2.1 mc, which you probably haven't got. The next best bet is to use a motor-driven sweep and connect the rotating condenser across the main tuning condenser of your test oscillator. Then set the combination so you sweep at 1050 kc and use the second harmonic. This will give you twice the sweep width you get at 1050 kc and will do the trick nicely. If you have an electronic type f-m oscillator, don't bother trying it. They are swell for a-m jobs but if you try to operate with harmonics you're due for some headaches . . . too many confusing beats. That is, if you use it in the normal manner. But, if you are experimentally inclined, and the fixed-frequency oscillator in your electronic type f-m oscillator operates around 800 kc, you can shunt a tuning condenser across it and tune it to

700 kc. Then kill the variable frequency oscillator and use only the third harmonic of the fixed-frequency oscillator. This will give you a sweep of about 120 kc at 2.1 mc—which is better than nothing, but not as much as is needed.

No matter which of these stunts you use, you need an oscillograph. If you have it, connect the vertical amplifier across *R1* and align as you would any set. If you don't have an oscillograph, there's another stunt which will work with any equipment. And here it is.

If you look at the small comparison diagram, Fig. 1B, you will see that the limiter and the diode detector circuit of a conventional set are much alike. They not only look alike, but, believe it or not, they do the same job. The diode rectifies and produces an a-f signal; so does the limiter input circuit. So all we need do to get the limiter to feed an audio signal through the a-f amplifier is to pull out the 6H6 discriminator and connect a clip lead from the high side of *R1* to the a-f input circuit, using a blocking condenser of about 0.1 mfd in series.

With this arrangement, you can connect an ordinary output meter across the voice coil or any other suitable portion of the a-f amplifier, feed a 400-cycle modulated signal to the input of the i-f amplifier and check the alignment. One good way of doing this is to vary the test oscillator frequency manually from 60 kc above 2.1 mc to 60 kc below this point. Watch the output meter as you do this. The pointer should rise to a maximum reading at 2.1 mc and fall off symmetrically on either side of this point. This applies to *Stromberg* and *G-E* sets now on the market. Others may come out with flat tops—which really aren't so necessary since the limiter flattens them anyhow—and may require different alignment.

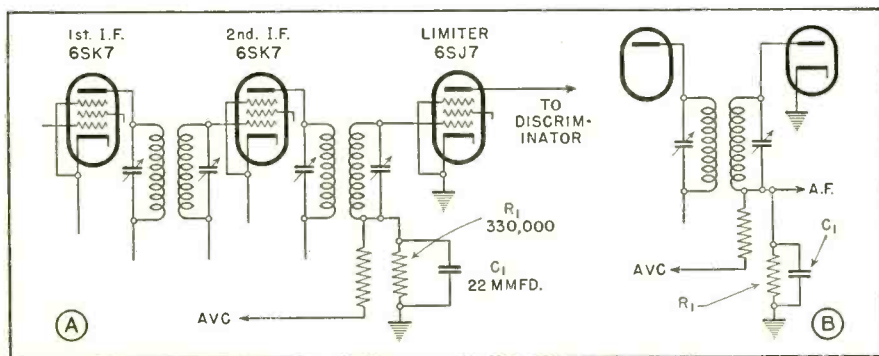

Fig. 1. (A)—limiter circuit in f-m receiver. (B)—diode detector circuit in a-m receiver. Both develop a.f. in the input circuit, which is handy for alignment purposes.

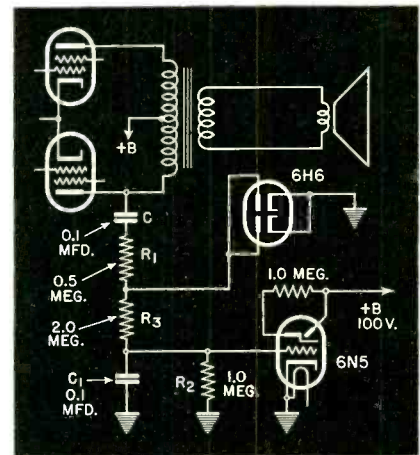

Fig. 2. Simple volume indicator for p-a systems.

In general, alignment is only required when there is trouble due to interference from a nearby powerful station, or after replacing a defective transformer. So don't worry too much about it.

VOLUME INDICATOR

THERE'LL BE LOTS of p-a work this summer and fall; and a volume-level indicator will come in handy when you have to put the loudspeakers far away from the amplifier gain control to avoid acoustic feedback. Often, as you know, some fellows get up to the mike and blow the audience out of their seats while others talk so low they have to hold their breaths to hear 'em, or give up in disgust, which is more likely.

You can tell just how much you're feeding the speakers by watching the 6N5. It is really like the avc circuit of the r-f and i-f sections of a receiver, but it operates from a.f. The audio signal voltage is fed through *C* and *R1* to the 6H6 diode, where it is rectified. The resistance-capacity filter, *R2-C1*, serves to smooth out a-f variations so that the indicator tube will not flicker on sudden bursts of audio but will follow the slower variations. By manipulating the gain control to keep the indications within desired limits, a reasonably constant sound level may be maintained. This is a modified version of a circuit used in sound recording.

TERMINATION IMPEDANCE

AN EXAMPLE OF THE 10-kc whistle filter, as used in a modern high-fidelity (Turn to page 32)

**A New
W-I-D-E**

R-A-N-G-E

**Signal
Generator**

**100 Kc
TO
120 Mc**

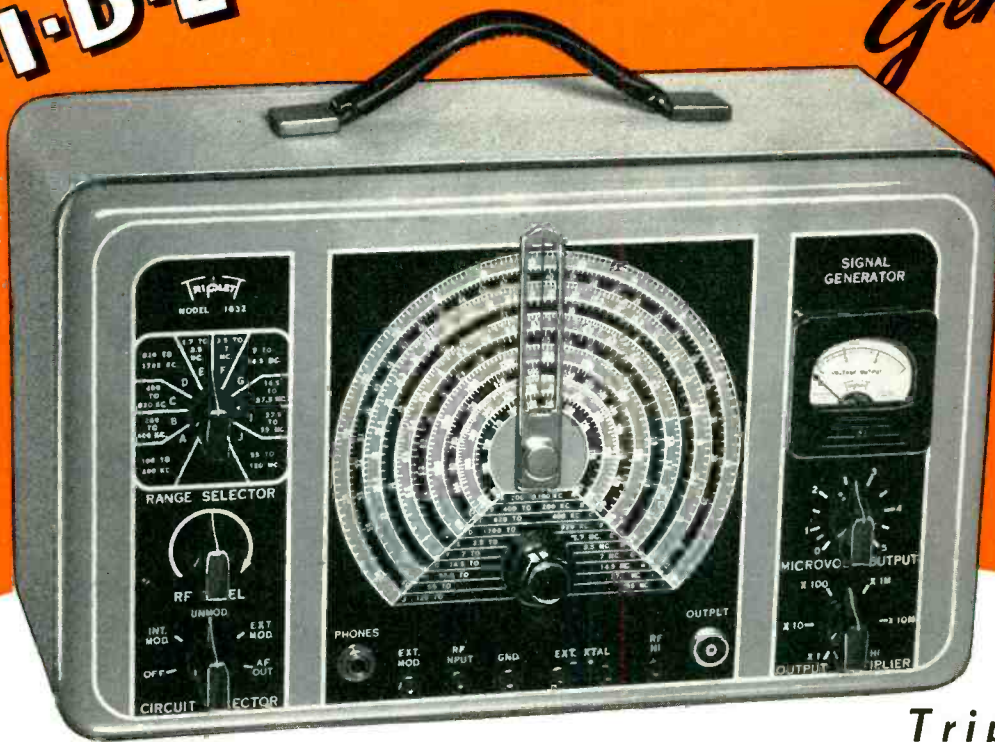

A COMPLETE Range Signal Generator . . . From 100 Kc to 120 Mc (10 Bands) . . . All frequencies in fundamentals. Continuous coverage of standard broadcast ranges as well as the new high frequencies for frequency modulated and television receivers. Direct meter reading in microvolts . . . Positive vernier dial tuning control—no backlash . . . Output available at end of coaxial cable speeds work . . . Operates from 110-220 Volt AC line 50 or 60 Cycles . . . Heterodyne detector incorporated . . . Provision for external

modulation at audio or radio frequencies . . . Permeability adjustment and tubular air-trimmer capacitors used throughout, assuring excellent accuracy and stability of dial scale calibration . . . Low resistance copper shielding. Furnished in rolled edge metal case, 15" x 9" x 6 3/4" . . . Dealer Net Price . . . \$79.84. For Catalog Write Section 476 Harmon Drive.

**Triplet
MODEL
1632
\$79.84
DEALER NET**



Model 1612 Counter Type Tube Tester

An impressive Counter Tube Tester you will want to own . . . **RED • DOT** Lifetime Guaranteed Instrument . . . Illuminated Roll-Dex Speed Chart . . . contains all tube sockets to test present day tubes including Locals, Ban. Jr., and the 1.4 volt Miniatures. Provides for future filament voltages—20 steps from 1.1 to 110 volts. . . Dealer Net Price . . .

\$29.84

★★★
ONE OF THE LITTLE TRIPLETTS

Model 670 AC
Ammeter . . .
Molded Case . . .
Self-contained
Transformer . . .
Ranges: 0-1-2.5-
5-10-25 Volts.
The little
tester with the
big 3" meter.



(13 in the family)

THE TRIPLET ELECTRICAL INSTRUMENT COMPANY

Bluffton, Ohio

Shop Notes

CROSLEY MODELS 689 and 729

Alignment Precaution

In these receivers, the 2.3- to 2.5-mc police band is covered by resonating the tapped loop at 2.4 mc and using the image frequency, which is 910 kc in both cases.

Model 689: When shunt aligning the short-wave band, care should be exercised so that the circuits will be aligned on the fundamental rather than the image which is 910 kc more than the fundamental. To check on this, increase the signal generator output about ten times and try to tune in the signal both at the signal generator frequency as indicated on the tuning dial, and at approximately 910 kc less than the correct frequency (18-mc fundamental, 17.09-mc image). If circuits have been properly aligned, the signal can be tuned in at both positions but with a much stronger signal on the fundamental.

Model 729: Same as above. The 2.3-to 2.5-mc police band in some of these models has no adjustment, but can be checked by using a .0001-mfd condenser in series with the signal generator output lead. With bandswitch in "Pol." position and signal generator set to 2.5 mc, the signal should come in with the receiver dial pointer near the end of that band.

STROMBERG-CARLSON NO. 460-PF

Phonograph Compensation

The engineering data given in the No. 360 Data Book may be used for the No. 460 receivers. The aligning information, diagrams and general instructions are essentially the same.

A volume-control motor is installed in these receivers and a remote-control unit identified as P-31860 may be easily connected if it is so desired. This unit permits the operation of the receiver at a remote point.

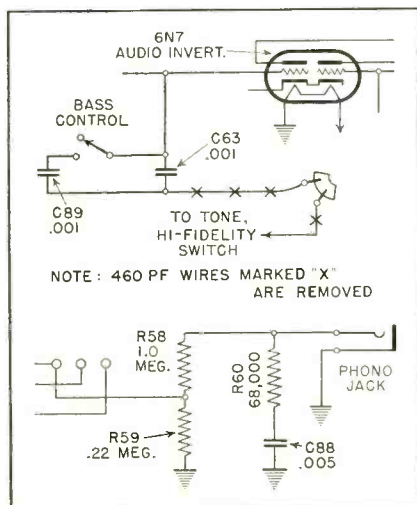

Additional phonograph compensation has been added as shown in the accompanying diagrams.

STEWART-WARNER 01-6C9, 010-6C9X

Tone Control Circuit Changes

The tone control circuit in most receivers of this model is shown in the latest bulletin. Chassis employing this type of tone control circuit are stamped with the letter "S."

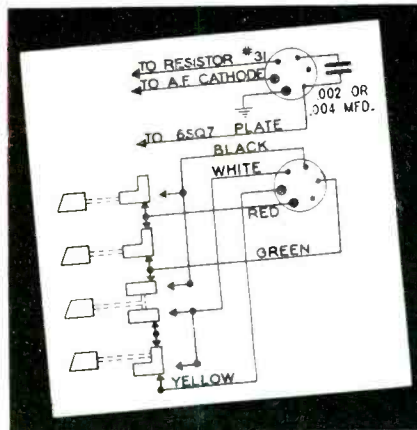

In the accompanying diagram is shown a tone control circuit used in some early receivers. A few receivers incorporate a tone control circuit differing from both circuits. In these cases, it is suggested that the serviceman revise these earlier circuits so as to convert them to the tone control circuit illustrated.

In some chassis, Resistor No. 31 was 22,000 ohms instead of 47,000 ohms. If this lower value resistor is replaced by the 47,000 ohm unit, an improvement in tone will result, especially noticeable on higher volume.

Important: Servicemen are cautioned not to interchange radio chassis indiscriminately in these receivers. The tone control circuit of an early receiver will not operate with a chassis of the later type (Stamped "S") and vice versa. Should it be necessary to interchange chassis and tone control assemblies, change the connections of the switch or of the set to conform to the circuit diagram.

Phonograph Pick-up Circuit Changes

Some of the earlier chassis of this model did not include the 220,000 ohm resistor or the 0.001 mfd condenser, which are connected across the pick-up. If either of these units are missing, or are of a value different from that specified, the insertion of the proper units will improve the tone when records are being played.

Audio Whistles or Growls

Growls in this receiver are caused by failure to loosen the shipping bolts on the receiver chassis and record changer mechanism. To eliminate these growls remove the two red shipping bolts holding down the record changer mechanism. These bolts are accessible from the rear of the cabinet and are located on both sides of the mechanism. Also loosen the three bolts holding down the chassis so that their heads

no longer touch the wood, and the chassis floats freely on the rubber bushings. Make sure that shafts of controls do not bind on the cabinet.

Whistles in a receiver stamped "S" are caused by feedback in the tone control circuit. To eliminate this difficulty, see that the red lead from the tone control switch is kept away from the other leads of that cable. Also make sure that the .01 mfd condenser, 34, located at the tone control switch, is kept as far as possible from the cable.

STEWART-WARNER

Wiring Color Code

In order to simplify the tracing of wiring, Stewart-Warner is using the following color code for all recent chassis wiring. Every effort is made to follow this code, though occasionally exceptions must be made.

GREEN	Grid
YELLOW	Plate
ORANGE	Cathode
GREEN & WHITE	The avc diode and avc circuit
GREEN & BLACK	Detector diode
BLUE	Ungrounded heater or antenna
BLACK	Ground, grounded heater and grounded B minus
BROWN	Ungrounded B minus
RED & BLUE ..	B plus (filter input) usually over 300 volts d.c.
RED ..	Normal B plus, usually 200 to 300 v.
RED & WHITE ..	Intermediate B plus, about 100 to 250 v. other than screens.
WHITE	B plus, about 100 volts (on screens only)

WELLS-GARDNER 5D2, 6A26, 6A27

Reduction of Hum

If hum modulation is noticeable on stations of weak signal strength, the condition may be corrected as follows:

Disconnect the .05-mfd grid return condenser (C1 in 5D2 and 6A26 series diagrams, C2 in 6A27) from the chassis ground and connect this side of the condenser to B-, the point marked "X" in the accompanying schematic.

On later production sets, this change has already been made.

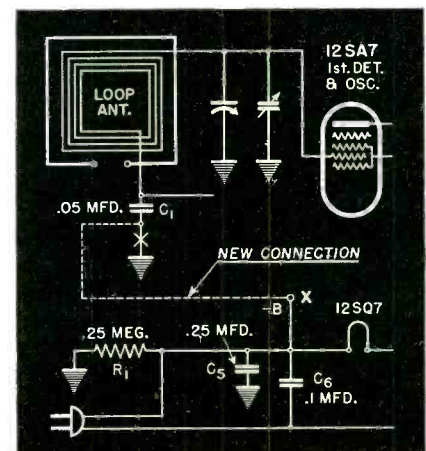

Presenting —

NEW PRODUCTS

SUPREME

Model 543 Multimeter—Pocket meter with bakelite case and two-color panel, full-size 3" one-mil meter. Single switch provides ranges of: *Resistance*—0/2000/200,000; *D-C Current*—0/6/60/600 ma; *A.C.*—0/15/150/600/3000 volts; *D-C.*—0/15/150-600/3000 volts. Batteries furnished and contained within case. Ranges at 1000



ohms/volt *standard* sensitivity. By Supreme Instruments Corp., Greenwood, Miss. RADIO SERVICE-DEALER.

SOLAR

Capacitor Analyzer—Checks on condensers while in circuit. Model BQC tells if condenser is bad, open, shorted or intermittent. Also indicates r-f impedance and power factor. Built-in Wien Bridge gives separate capacity measurements from .00001 to 70 mfd.



Model QC incorporates all the above features except those of the Bridge. Complete data may be had from Solar Mfg. Corp., Bayonne, N. J. RADIO SERVICE-DEALER.

RCA MFG. CO.

No. 167 Test Oscillator—Advanced model of the earlier 153 RCA Oscillator, with the addition of an output cable and new type pointer.

Fundamental frequency range is 100 to 30,000 kc. Dial scale is 6¼" in diameter, 50" in length. External frequency modulation may be added for the oscillographic method of servicing.



Has 400-cycle output of 8 volts for audio circuit testing. The r-f output is 1 volt. Other features: six bands, minimum signal of 2 microvolts, negligible leakage. By RCA Manufacturing Co., Camden, N. J. RADIO SERVICE-DEALER.

SIMPSON

3-Unit Analyzer—For measuring electrical loads in all servicing or production testing. Three small matched meters are included in a sturdy carrying case. Available in combinations to measure current, voltage and resistance for practically any requirement.

Each of the nine "Micro-Testers" from which a selection of three may be made, is housed in a red moulded bakelite case, with satin-finished steel front panel. Each measures 5¼" x 2⅞" x 1¼" and none weighs more than 20 ounces.

The following units are available: Model 280 Multiple-Range A-C Ammeter, Model 281 A-C Voltmeter, Model 282 D-C Ohmmeter, Model 283 D-C Milliammeter, Model 284 D-C Microammeter, Model 285 D-C Ammeter, Model 286 A-C Voltmeter, Model 287 D-C Voltmeter, Model 288 A-C



Milliammeter. By Simpson Electric Co., 5216 W. Kinzie, Chicago, Ill. RADIO SERVICE-DEALER.

HICKOK

Jumbo Volt-Ohm-Milliammeter—Model 4922-S is a 9½" rectangular meter with large open face scale. Ranges are: a-c and d-c volts, 0-10/50/250/500/2500; d-c microamps, 0/500; d-c milliamps, 0/5/50/500; ohms, .05/30, .5/10,000, 50/1 meg, 500/10 megs; db, -10 to +15, 29, 43; output, 0/10/50/250/500/2500.



There is a potentiometer adjustment for change in ohmmeter battery voltage. Instrument incorporates new type rectifier circuit which will withstand greater overload. By Hickok Electrical Instrument Co., Cleveland, Ohio. RADIO SERVICE-DEALER.

WEBBER

Tube Tester—The Model 150 Tube Tester, just added to the complete Webber line is offered at a low price. It is said that this instrument will be particularly popular during the spring and summer months when the need for low price, portable instruments is highest.

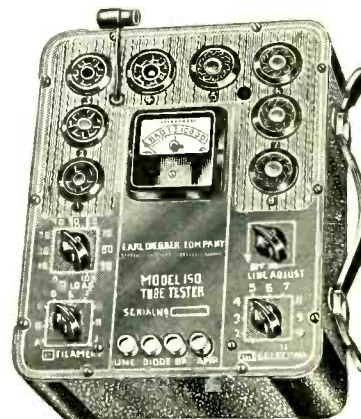

A technical description of this instrument may be secured by writing the Earl Webber Company, 1313 W. Randolph Street, Chicago, Ill. RADIO SERVICE-DEALER.

CATALOGS - BULLETINS

Du Mont Oscillograph—Bulletin describing features of new Du Mont Type 208 Cathode-ray Oscillograph. Contains 8 pages in two colors. Write Allen B. Du Mont Labs., Inc., 2 Main Ave., Passaic, N. J.

Parts Catalog—List price catalog for the radio trade with manufacturer's index and order blanks. Comprehensive listing of hundreds of parts. Issued by Momsen-Dunneagan-Ryan Co., El Paso, Texas.

Parts Catalog—Catalog containing 180 pages, with "telephone-book" punch for attaching to desk or counter. For distribution in northeastern Michigan. Issued by Radio Tube Merchandising Co., 508 Clifford St., Flint, Mich.

Parts Catalog—New, 216-page catalog of radio parts and equipment, with two-color cover. For distribution in North Carolina and Southern Virginia. Issued by Brower Electric Supply Co., Inc., 312 N. Eugene St., Greensboro, N. C.

Webber "Blue Book"—An 8-page booklet titled "Blue-Book of Instrument Values" to give radiomen "a better means of judging value offered in 1940 service instruments." Issued by Earl Webber Co., 1313 W. Randolph St., Chicago, Ill.

Matching Speakers—Booklet covering manner of matching speaker systems to amplifiers, and similar problems. Issued by John Meck Industries, Randolph at Elizabeth St., Chicago, Ill. No charge.

Tube Sales Aids—Scores of sales aids from neon counter and window signs to a series of direct-mail postcards are included in the Sales Aid Catalog just issued by RCA Manufacturing Co., Camden, N. J.

SALES APPOINTMENTS

Du Mont-Crossley—Alfred Crossley, of 549 W. Randolph St., Chicago, will henceforth represent Allen B. Du Mont Labs., Inc., in a sales engineering capacity in the Chicago area.

Erwood-National Union—A contract has been entered into by the Erwood Sound Equipment Company, of Chicago, and the National Union Radio Corporation, of Newark, N. J., whereby National Union becomes exclusive Sales Agent in the United States for Erwood Sound Systems. All sound systems will be manufactured and advertised by Erwood. National Union will handle all matters pertaining to sales. The Erwood line will be merchandised through jobbers and dealers, independent of National Union.

DeWald-Nidisco—DeWald Radio Mfg. Corp., New York, announces the appointment of Nidisco, Inc., as the distributors of the DeWald line in the state of New Jersey.

(Turn to page 25)



Have you stopped to THINK what F-M means to YOU?

and have you considered
the amazing Profit-Possibilities that are yours
with the New Meissner

FREQUENCY MODULATION RECEPTOR

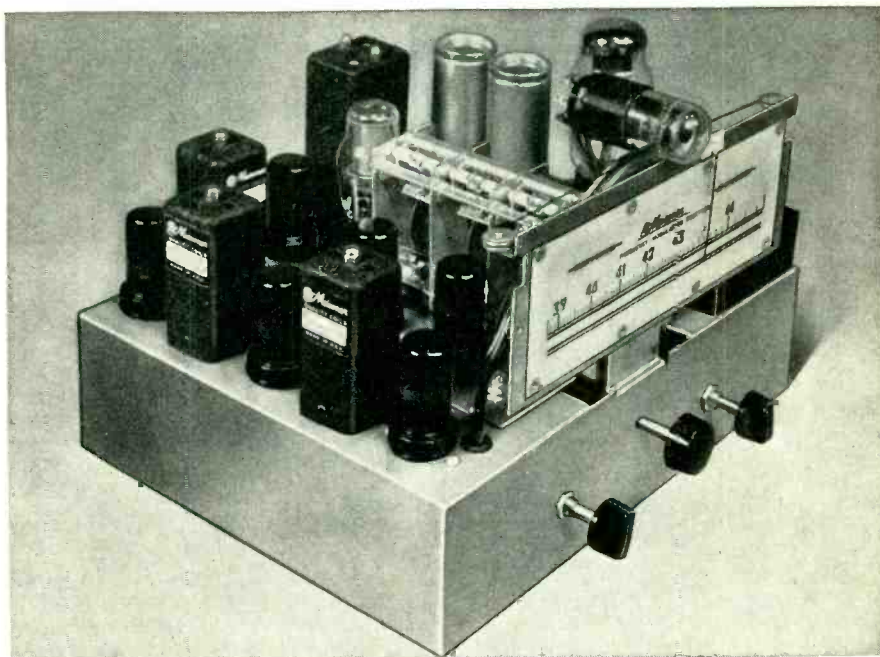

It's easy to figure out—

It certainly doesn't require a lot of mental gymnastics to ascertain the obvious—the fact that Frequency Modulation is here—and here to stay!

The big question is—how soon are YOU going to start cashing in on the increasing demand by the music-loving public for noiseless, static-free reception? The stage is all set—new stations are being built all over the country—commercial licensing isn't far off—AND, the Meissner F-M Receptor is all ready to begin the first act!

Here's an opportunity you must not neglect—the first real chance to get in on the ground floor since the beginning of radio. The Meissner Receptor provides highest quality F-M reception on any radio—feeds the audio system of any good receiver. If a separate F-M receiver is desired—just add the simple audio system to the same chassis.

The Receptor is completely wired and tested—all ready to go (except tubes), with complete instructions for adding the audio system. Investigate the F-M possibilities in your territory NOW! See your Jobber at once or write for further details.

INSTRUCTION MANUAL

Get your copy of this big NEW 168-page book, "How to Build Radio Receivers". Contains added material on Frequency Modulation theory and design principles as well as complete instructions on the Receptor. See your Jobber or send 50c at once to the address below. Order it today!

COMPLETE CATALOG FREE

Meissner's entire line of receiver components and complete kits is described and illustrated in this big 48-page catalog. Over 600 items of vital interest to the serviceman and experimenter. Write for your free copy today. A postal card will do!

ADDRESS DEPT. D-6



New Products

DU MONT

Type 208 Oscillograph—Supplied with intensifier-type cathode-ray tube utilizing electrostatic focusing and orthogonal electrodynamic deflection. Gas-discharge type relaxation oscillator provides sweep circuit for delineation of unknown signals as a linear function of time.

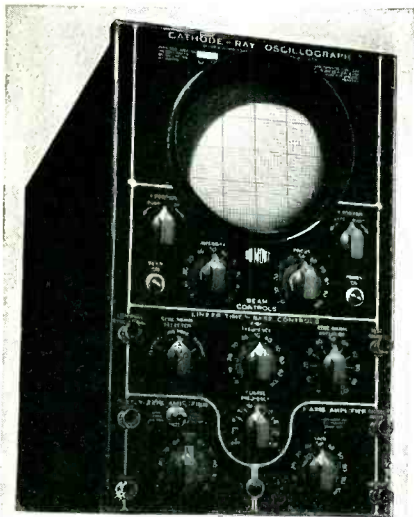

Frequency response rating of instrument is independent of attenuator settings. New deflection-amplifier coupling circuit eliminates "electrical backlash" in the position-control circuits. By Allen B. Du Mont Labs., Inc., 2 Main Ave., Passaic, N. J. RADIO SERVICE-DEALER.

RADIOTECHNIC

Model 120 Tube Tester—Has "permutation" switch system designed to accommodate any possible combination of heater and control elements of all existing sockets, and for all tubes that may be introduced in the future. Space is provided for new sockets.

All tubes, including loctal, single-end, miniature, Hytron Bantam, Raytheon CK series, 50, 70 and 117-volt series, pilot lamps and Xmas tree bulbs can be tested. Gaseous rectifiers are also tested with proper operating voltages.

Three d-c ranges of 0/10/100/1000 volts are available for the testing of batteries and power supplies.

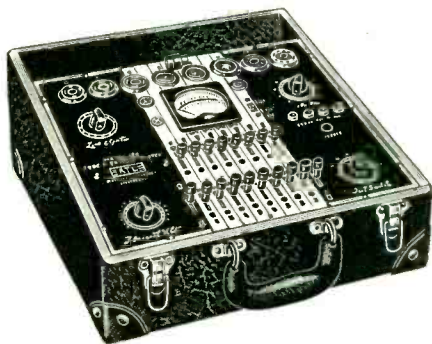

Model 120 is available in a counter and portable model. Portable model is shown. By Radiotechnic Laboratory, 1328 Sherman Ave., Evanston, Ill. RADIO SERVICE-DEALER.

LAFAYETTE

"Talking Car" Unit—For police traffic cars, etc. Has sound projector to overcome outdoor noise. Amplifier mounts under dashboard of any car. Has tone and volume control.



Amplifier designed for either 6 volts d.c. or 110 volts a.c. Separate plugs obviate possibility of error. Battery drain: 6 amperes under full load; 1 ampere with amplifier set in stand-by position.

Speaker is a miniature marine re-entrant type. Equipped with a metal mounting bracket for under-hood installation. By Radio Wire Television, Inc., 100 Sixth Ave., New York, N. Y. RADIO SERVICE-DEALER.

PIONEER

Rotary Converters—Available with or without filter for converting 6, 12, 24, 32, 48, 110, 220 or any special d-c voltages, to 110 or 220 volts a.c. Capacities: 40 to 5000

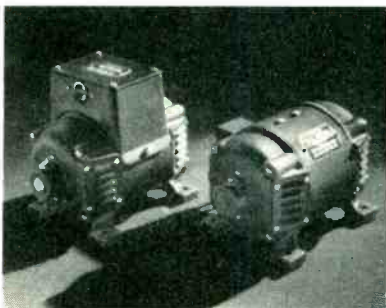

watts. By Pioneer Gen-E-Motor Corp., 466 W. Superior St., Chicago, Ill. RADIO SERVICE-DEALER.

PRESTO

Model K Recorder—Portable recorder complete in a single unit. Cuts 6, 8, 10 and 12-inch records at 78 r.p.m. (Model K-7 at both 78 and 33 1/3). Cuts 100 lines per inch, inside-out or outside-in as specified.

Features are: magnetic cutting head and pickup, 6-tube amplifier, detachable dynamic speaker, safety cam lever for lowering cutting head, enclosed cutter feed mechanism, rubber-tired turntable, xtal mike.

Response of amplifier, 50 to 8000 cycles; pickup and cutting head, 80 to 5000 cycles. Noise level 35 db below maximum useful sound level. Amplifier has gain of 110 db

and output of 3 watts. Turntable speed accuracy within 0.4%; regulation within one revolution is accurate to 0.2%. By Presto Recording Corp., 242 West 55th St., New York, N. Y. RADIO SERVICE-DEALER.

GENERAL CEMENT

Carbon-X—A compound for application to noisy carbon volume controls, tone controls, etc. A little is applied to the defective spot on the control element. Comes in 2-ounce bottles. By General Cement Mfg. Co., Radio Division, Rockford, Ill. RADIO SERVICE-DEALER.

TECHNICAL APPLIANCE

Master Antenna—New system provides for an expanded frequency range to include f-m reception. Use of high-frequency iron-dust cores, permitting isolation of primary and secondary transformer windings, improves signal/noise ratio.

Master roof unit has been changed over from unbalanced doublet to an L-type

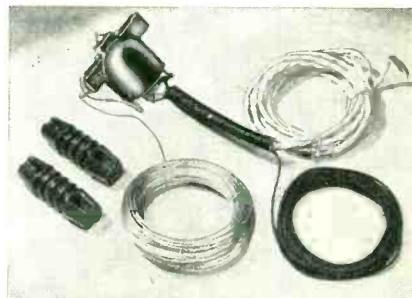

aerial. The number of set couplers that may be fed by one master antenna is 15 to 25.

The Home Antenna System kit has also been revamped, and has an operating range of from 150 kc to 75 mc. A Store Demonstration Antenna System, with the same features as the Master Antenna, is also available. By Technical Appliance Corp., 17 East 16th St., New York, N. Y. RADIO SERVICE-DEALER.

IDEAL

"Quick Heat"—Soldering iron with carbon electrode heating element. This electrode makes contact at point of tip so that heat is concentrated where it is most effective. Heating is controlled by a thumb-operated button on handle. Heating stops when button is released. Soldering heat in less than a minute.

Iron not recommended for continuous duty. Complete assembly includes transformer, soldering iron and leads. By Ideal Commutator Dresser Co., 5104 Park Ave., Sycamore, Ill. RADIO SERVICE-DEALER.

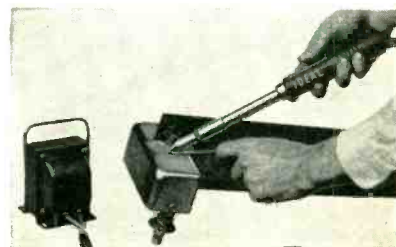

(From page 23)

Triumph-Fry & Roberts—A complete line of testing instruments are now stocked on the West Coast by *Fry & Roberts*, Los Angeles, Calif., representatives of *Triumph Mfg. Co.*, Chicago, to provide immediate deliveries to jobbers in the Pacific States.

Clarion-James—Transformer Corporation of America, New York, announces the appointment of *R. C. James*, of the Northwestern Agencies, 2411 First Ave., Seattle, Wash., as Sales Representative for the Northwestern territory.

Clarion-Gerber—Transformer Corporation of America, New York, has appointed *H. Gerber*, 49 Portland St., Boston, Mass., as Sales Representative for Clarion in the New England territory.

New RCA Jobbers—The *Wyatt-Cornick Company*, at Richmond, Va., and *The Yancey Company, Inc.*, of Atlanta, Ga., have been appointed new wholesale distributors of RCA Victor radios, Victrolas, receiving tubes, and Victor and Bluebird records.

The *Strauss-Frank Company*, of San Antonio and Houston, Texas, has been appointed distributor for all RCA Victor products in the South Texas area.

NRPA Additions—The following concerns were recently added to the membership roster of the National Radio Parts Distributors Association: *Connecticut*—Radio Inspection Service, Hartford. *Michigan*—Wedemeyer Radio Co., Ann Arbor; M. N. Duffy & Co., Detroit; Radio Tube Merchandising Co., Flint; Shand Radio Specialties, Flint; Toledo Radio Specialties, Toledo.

SOUND RECORDING

(From page 7)

"Shorts" and "Echoes": These two faults, as pointed out in the first article, can only be caused by poor grade recording blanks that are too soft to be used with any degree of satisfaction, or by attempting to record at too high a volume level.

Record Wear: It should be remembered that instantaneous recordings do not have the same resistance to wear as do commercial pressings. But, if the records seem to have short life, it is unquestionably due to the use of poor recording blanks, or a pickup that is too heavy or too stiff. Rapid wear may possibly be due to a pickup whose arm is not free in its mounting. Or the use of improper playback needles.

Overcutting: In many cases, this is not due to excessive recording level, but to "twinning" of record grooves. This improper groove spacing cannot be easily corrected. The entire mechanical drive

(Turn to page 27)



Only the finest reproducers assure profitable sound installations.

RACON is the ultimate in quality—easiest to sell—gives the greatest dollar value obtainable.

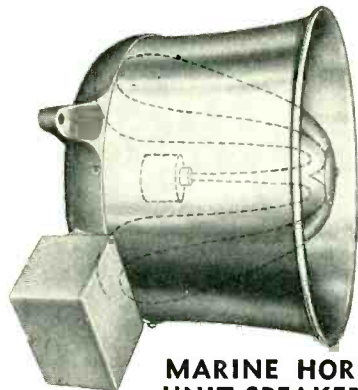

MARINE HORN UNIT SPEAKERS

Re-entrant type speakers using horn type units for marine and general P-A applications—may be used as loudspeaker or as a microphone. Miniature and regular sizes approved by the Bureau of Marine Inspection and Navigation, Department of Commerce, for marine work. In all sizes, miniature, midget, regular and bull, handling from 5 to 50 watts.

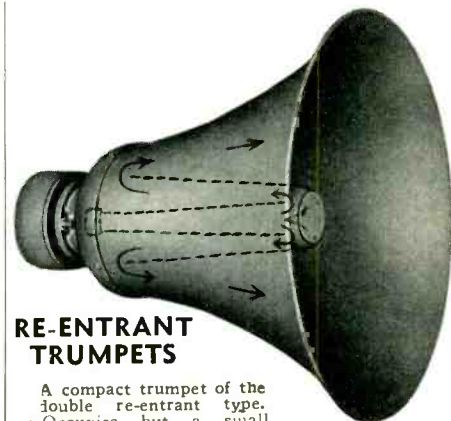

RE-ENTRANT TRUMPETS

A compact trumpet of the double re-entrant type. Occupies but a small space, nevertheless has a long air column enabling it to deliver highly concentrated sound of the greatest efficiency over long distances. Base and inside cone arm made of aluminum castings, outside bell of heavy gauge aluminum spinning, center section of RACON ACOUSTIC material to prevent resonant effects. Available in 6", 4 1/2", 3 1/2", and 3" air column units.

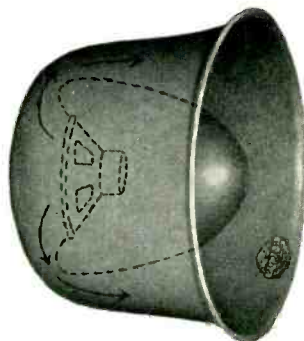

Marine Cone Unit Speakers

Re-entrant type speakers of the marine type using cone type driving units for indoor and outdoor applications. Bell made of heavy gauge aluminum, cone mounting made of aluminum casting, and center bullet of RACON ACOUSTIC material to prevent resonant effects. Material stormproofed for all weather conditions. Baby size for 2" or 3", miniature for 5", regular for 8", and giant for 12" speakers.



PAGING HORN

A small, extremely efficient 2-foot trumpet speaker, for use where highly concentrated sound is required to override high noise levels, such as in factories, outdoors, etc. Uses a small, very efficient Permanent Magnet unit. Particularly adaptable for paging systems, hotel lobbies, trucks, etc. Horn made of RACON ACOUSTIC storm-proof material with a beaded edge around the bell. Cast aluminum tone arm. Unit covered with aluminum case. Bell diameter 12"; overall length 29".

Super Giant P. M. Horn Unit

Operating capacity 12-15 watts, peak 25 watts. Other P.M. Units available, from the "baby unit" of 5 watts to the "bull unit" with an operating capacity of 50 watts. Efficiencies of the highest order obtainable with the finest magnetic material and steel utilized.



finest magnetic material and steel utilized.

A few territories still open to outstanding distributors. Complete literature and prices upon request. Write today!

RACON ELECTRIC CO.

52 East 19th St.,

New York, N. Y.

Visit the RACON BOOTH at the Trade Show

New Products

COLE

"Instansolder"—No. 39 Electric Soldering Outfit, providing soldering heat in 17 seconds. Heat is developed by a small arc of

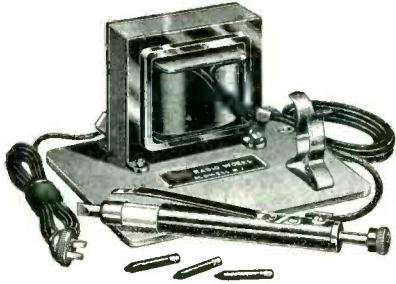

low voltage and high current. A carbon electrode, supported on the movable center rod, contacts the upper end of the copper soldering tip. Soldering about equal to 75-watt electric iron.

The iron has a bakelite shell, with insulantite insulator supporting the tip. The transformer, and spring clip for holding the iron, are mounted on a Masonite base. Supplied with 10-foot cord. By Cole Radio Works, Caldwell, N. J. RADIO SERVICE-DEALER.

ELECTRO PRODUCTS

A-B Vibrator—Operates on any 6-volt d-c power source. Model Q operates any 1.5-volt radio with 4, 5 or 6 tubes. A synchronous vibrator system supplies 90 volts B at 13 ma.



Model R is available for 2-volt sets using 4, 5, 6, or 7 tubes, and supplies 67, 90, 112, and 135 volts B at 20 ma. By Electro Products Labs., 549 W. Randolph St., Chicago, Ill. RADIO SERVICE-DEALER.

CLAROSTAT

Speaker Output Attenuator—A distortionless means of controlling the volume of individual loud-speakers in a sound system, is provided by the new Series CIB output attenuator. Capable of dissipating 10 watts at any setting.

One-hole mounting, round black-and-



silver etched dial, pointer knob, this unit may be installed in power amplifier or at the individual speaker. Insertion loss is below zero. Range is in 3 db steps up to 24, and then a 6 db step, with final step to infinity. Stock ohmages are 8, 15, 50, 200, 250 and 500 ohms. These units do not come equipped with power switches. By Clarostat Mfg. Co., Inc., Brooklyn, N. Y., RADIO SERVICE-DEALER.

RCA MFG. CO.

"Accordion Edge" Speaker—Makes use of a folded or "accordion edge" cone support which permits cone to move more freely when driven by a p-m mechanism.

Overall dimensions, 7" in diameter, 4" deep. Weight, 3 lbs. Frequency range, 80 to 7000 cycles. Power-handling capacity,

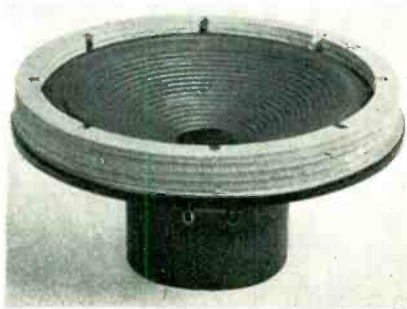

3 watts continuous. Voice-coil impedance, 6 ohms. By RCA Manufacturing Co., Camden, N. J. RADIO SERVICE-DEALER.

DUCON

"Solder Master"—Solder is delivered a drop at a time by depressing a trigger. The drop issues from a small tip under the reservoir pot on the tool head. Size of solder drop is controlled by button on handle. Spill-proof cup holds 48 average drops of solder.

Assembly includes a half-inch screw tip, 60-watt heating element, 6-foot cord with rubber plug. For 115 volts a.c.-d.c. By

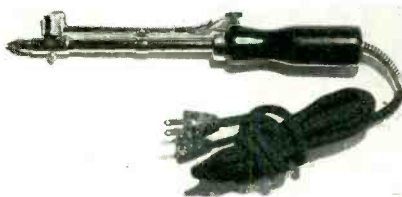

Dual Remote Control Co., Inc., 31776 W. Warren, Wayne, Mich. RADIO SERVICE-DEALER.

TERMINAL

T-8 P-A Amplifier—Output of 8 to 10 watts for 500 persons indoors, 3000 square feet coverage outdoors. Has two high-impedance input channels for mike and record player, with mixing and fading features.

Frequency range, 40 to 10,000 plus or minus 2 db. Distortion, less than 5% at 8 watts, 7% at 10 watts. Inverse feedback is employed.

A tapped output transformer provides voice-coil and line impedances of 2, 4, 6,



8, 16 and 500 ohms. By Terminal Radio Corporation, 68 West 45th St., New York, N. Y. RADIO SERVICE-DEALER.

AEROVOX

Plug-In Electrolytics—Units can be instantly removed, tested and replaced where needed. Employ octal bases, fitting the standard octal socket. Base has nickel-plated brass prongs engaging similar socket contacts. The prongs join with aluminum studs.

The can may be negative, at cathode potential, or left floating. Negative or cathode-connected can may be grounded by means of a ring lug.

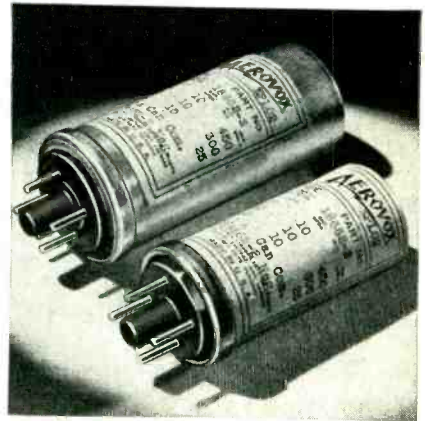

Series AP plug-in electrolytics are available in either etched foil or plain foil, in two can diameters, 1 3/8" and 1 5/32", and in heights from 2 1/2" to 4 1/4". One to three sections can be included in the cans, using number pin for common negative, or four sections can be included with the container as common negative. By Aerovox Corporation, New Bedford, Mass. RADIO SERVICE-DEALER.

SUPREME

Hi-Voltage Test Leads—Type 4875, designed to extend d-c voltage range of Model 549 Electronic Voltmeter to 6000 volts. Tested at 10,000 volts.

Cable is No. 18 stranded tinned copper wire with heavy rubber insulation. Large handles made of bakelite. Testing prods about 6" long with 2" prods on opposite ends. Cable length about 5 feet.

Part of multiplier is incorporated in probe, serving to isolate probe from circuit under test. Total resistance in probe is calibrated to $\pm 1\%$. By Supreme Instruments Corp., Greenwood, Miss. RADIO SERVICE-DEALER.

Playing Safe...



- ★ More and more servicemen are using CLAROSTAT controls. Many have come back to CLAROSTAT after trying others. They are simply playing safe, because:
- ★ CLAROSTAT offers the most extensive and accurate control replacement data in its new 1940 Service Manual now being distributed by our jobbers, free of charge, to servicemen.
- ★ CLAROSTAT is backing that Service Manual with the largest line of exact-duplicate and standard controls.
- ★ CLAROSTAT controls reflect constant refinement even in the smallest details, so that today they are mighty hard to beat. A trial will convince you.
- ★ AND CLAROSTAT selects its jobbers on the basis of how well they can serve you locally. CLAROSTAT jobbers are, therefore, worth knowing and doing business with.

Get Your Copy . . .

The latest Clarostat Service Manual is available from your local jobber. Ask for it. Costs you nothing.

Also, there's the Clarostat Plug-In Resistor Tube Service Manual. Right up - to - the - minute. From your jobber—15c per copy.



CLAROSTAT MFG. CO., Inc.
Dept. S1, 285-7 N. 6th St., Brooklyn, N. Y.



(From page 25)

and feed assembly must be checked for freedom of movement.

Sometimes standard records will play satisfactorily, but when an instantaneous record is played, it repeats. Be sure that the pickup arm is free in its movement and that the pickup cartridge is of sufficiently high compliance to properly track the softer instantaneous records.

Speed Fluctuation: The source of any speed fluctuation or "wow" must be traced to determine its cause. If the turntable wows with an instantaneous record but not with a commercial record, it is losing torque when the additional load is encountered, when recording. If the turntable is friction-driven, be sure the idler wheel is not excessively worn. Tighten the tension spring on the idler. If the turntable is gear-driven, clean the motor thoroughly and oil all moving parts.

Although it was said in the first article that there is no visual check for speed fluctuation, this is not strictly true. The process of checking entails the following: A constant-frequency record must be made from the output of an audio oscillator. If there is no wow present, the "crests" and "valleys" of the sine wave from the a-f oscillator will form a regular pattern across the record and in a line reasonably approaching a radius of the circle. If wow is present, the pattern will be very irregular, approaching the herringbone effect indicated on the surface of the record illustrating 120-cycle hum, shown in the first article.

Pitch Change: If there is a change in pitch during playback, it is more than likely caused by slippage of the idler wheel, or loss of torque by the motor. Use a stroboscope disc to set the turntable to proper speed and constancy after adjustment.

Poor Quality: Discourage the habit of holding the microphone too close to one's mouth. Most rooms are acoustically dead and the average microphone supplied with home recorders are non-directional so that there is no necessity of worrying about echo or reverberation. Although many of these microphones are not of the highest quality, very little is to be gained by substituting a more expensive one unless the recording equipment has a wide frequency range.

"Skating": If the reproducing pickup skates across the record, either the pickup arm is not free in its lateral movement or the record grooves are too shallow.

Stylus Wear: The stylus is the cheapest item in record-making. The steel stylus cannot be expected to cut more than a dozen 10-inch records. The semi-permanent stylus is probably less expensive

Alliance "Even-Speed" PHONO-MOTORS

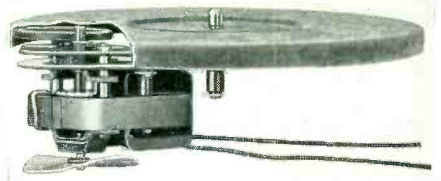

*"Even-Speed" Model 80
A Dependable Friction
Drive Motor at a Sensational Price.*

● Even-Speed Model 80 is available for operation on 110 or 220 volt, 50 or 60 cycle source at 16 watts input. Simple and quiet in operation—no gears—smooth, positive friction rim drive. Good regulation characteristics for uniformity of table speed. Amply proportioned bearings—large oil reserves. Motor and idler plate shock mounted to mounting plate for low vibration transfer to turntable and motor board. Forced ventilation for cool operation. Slip type fan precludes possibility of injury. Mounting plate maintains correct turntable height regardless of mounting board thickness. Available with 8, 9, or 10 inch turntable top. Maximum depth below base mounting plate, 2-1/16 inches.

Constant Speed

The name "Even-Speed" means constant speed under all normal load, voltage and temperature variations. The Model 80 shown above is just one of several, precision built phonograph motors now being made by Alliance. Each is a quality motor and built for years of service.

Write For Service Hints

Write today for complete information on Alliance Phono-Motors, and also for a reprint of a valuable article on Servicing Friction Drive Phono-Motors, prepared by Porter Turner, one of Alliance's engineers, and appearing recently in a leading radio trade paper.

Address Department R

ALLIANCE MFG. CO.
ALLIANCE, OHIO

LIFETIME SOUND



LIFETIME CORP. now offers its products direct to the soundman. Now you can buy speaker units, horns, baffles, microphones, etc., direct from the manufacturer at remarkably low prices. Below we list a few of our outstanding values.

Model 40 PM Unit. Voice Coil—15 ohms at 1,000 c. Capacity—15 Watts continuous conversion. Field—of Lifetime exclusive Nipermag. List Price \$40.00



NET—\$16.00



Model 65 PM Unit. Voice Coil—15 ohms at 1,000 c. Capacity—24 Watts continuous conversion. Field—Lifetime exclusive Nipermag. List Price \$65.00

NET—\$26.00

TRUMPETS!

- Model 3 AT Trumpet—Length 3 feet—Diameter of bell 22". List Price \$22.50. Net \$9.00
- Model 4 AT Trumpet—Length 4 feet—Diameter of bell 24". List Price \$40.00. Net \$16.00
- Model 5 AT Trumpet—Length 5 feet—Diameter of Bell 24". List Price \$45.00. Net \$18.00
- Model 6 AT Trumpet—Length 6 feet—Diameter of Bell 32". List Price \$55.00. Net \$22.00
- Model 6 HP Trumpet Hi-Power—Length 6 feet. Special wide air column load. Diameter of bell 34". List Price \$70.00. Net \$28.00

MICROPHONES!

MODEL D 42 Dynamic Microphone—Output level, minus 52 DB. Input direct to grid. Frequency response 50 to 10,000 CPS. List \$27.50



NET—\$11.00



MODEL 80 Velocity Microphone—Output level, minus 54 DB. Input direct to grid. Frequency response, 48 to 12,000 CPS. within 2 DB. List \$21.00.

NET—\$8.40

SPECIAL OFFER!

All orders sent from this ad accompanied by remittance in full will be PREPAID!

Send for our complete catalog of microphones and sound equipment.

THE LIFETIME CORPORATION
1825 Adams St. Toledo, Ohio

over a period of time since it can be resharpened when worn.

Some record blanks will dull a stylus very quickly, others will not offer such a complaint. The relative hardness or softness of a record blank is no check as to its ability to be easily recorded upon. The variance in blanks is rather that of their coefficient of friction than their hardness.

MASTER AERIALS

(From page 5)

Make a sketch of just how the job is to be wired.

On your earlier jobs, don't hesitate to consult the manufacturer. He has had long experience in planning, estimating and handling such installations. He can help you work out the best installation. He can check over your estimates provided you supply the essential details. You can have real help in getting into this profitable field.

MINIMUM WORK

Realizing how vital it is to keep the labor down to a minimum, equipment has been constantly refined and simplified. Present kits now combine the aerial-line transformer and the lightning arrester in a single unit which is mounted close to the pole or other support. The transmission line is soldered to the transformer unit at the factory. The installation of the aerial proper is just a matter of stringing out the wire and connecting it to the end insulator which in turn is fastened to the supports.

The transmission line comes in any required length. No joints or connections are required for the line itself. At each floor level where an outlet is to be served, the two wires of the transmission line are bared for a few inches, and the wires from the outlet wrapped

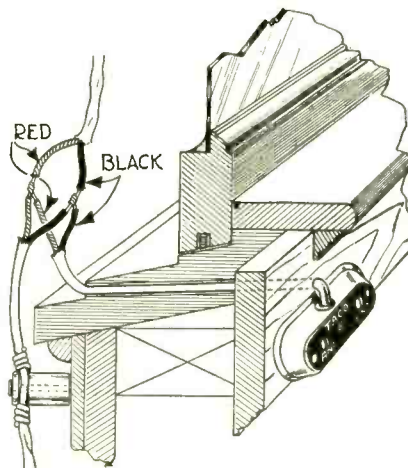

Detail of the coupler or outlet, mounted on inside window frame, connecting with outside transmission line.

around to make connections. Using black and red covered wires throughout the system, the installer simply can't go wrong when he always connects red to red and black to black.

The outlets themselves are entirely self-contained. The neat enameled cases with bakelite panels carrying the screw binding posts, are simply held to base-board or window sill by a single wood screw. It's all so simple.

TOOLS AND EQUIPMENT

Of course you'll need some tools. It's difficult to specify any particular equipment, for you'll work out your own needs as you get to them. However,

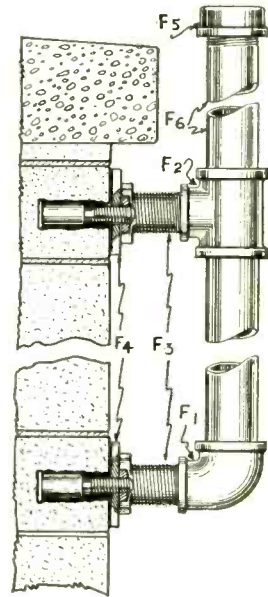

Suggested iron mast support. Note use of T and elbow, standard flanges, and lead-expansion studs for fastening to masonry.

one essential is an electric hand drill. It takes too long and it's too tiresome to drill holes through window frames with brace and bit or with a hand drill. A small electric jack hammer is mighty handy but not essential, in drilling holes into brick or other masonry for anchoring your pole supports. A calking gun may be needed if you are going to place wires in slots in the roof proper or in parapets or walls, and for sealing in the wires passing through window frames. And of course you'll need pliers, screwdrivers and other typical servicing tools.

You'll need ladders. You'll need ropes. And you'll need safety belts if working on tall buildings. Whatever you do, don't take unnecessary chances. It's a lot better to use safety belts than to land in a hospital bed or a coffin.

The finished job is readily checked before turning it over to the property owner. There are simple trouble-shooting rules if the finished job should not check just right, or if you are called upon later to service the job. But the

whole technique is so relatively simple that there's little trouble likely to turn up.

GETTING STARTED

As already intimated, this master-antenna-system business is pretty varied. You can start with private dwellings, if you wish. The average better-class home is a logical prospect. A single aerial can be made to serve several sets in the household. Note the accompanying sketch of a typical master-antenna installation.

Then there are the public buildings—apartment houses, hospitals, hotels, clubs and so on. Such jobs run up into hundreds and even thousands of dollars gross, with a correspondingly nice profit. Fortunately, you can more or less select the magnitude of your jobs. You can tackle the smaller ones first, getting your experience, before moving on to the larger ones. There are many single-aerial jobs to be done, and what you learn with these will serve to good purpose when you move on to the multi-aerial jobs serving dozens upon dozens of sets.

The very latest master-antenna-system is designed to include the ultra-high-frequency bands now coming into use for frequency-modulation receivers, as well as television reception. The couplers or outlet units in this case are provided with two sets of terminals, one for usual broadcast and short-wave bands, and the other for the f-m band.

And there you are. The opportunity is presented to you. Years of engineering and business experience are available to you. Standardized components are offered. Instruction manuals will guide you safely through the various details of surveying, estimating, installing and testing any master antenna installation.

If you want extra dollars, here they are.

HUDSON VACUUM AERIAL

DETAILS covering the installation of the vacuum-operated antenna (Kit No. 159201) on the 1940 model Hudson cars are given in the following paragraphs. The various operations should be carried out in the order in which they are presented.

Remove left cowl side panel. Locate hole on left side of cowl with template provided (See Fig. 1) and center punch at point indicated.

Drill a 1/8" hole at center punched location and complete hole with a 7/8" cutter. *Be sure drill is held in vertical position.*

Drill a 3/16" hole in body left front pillar to dash bracket 3/4" below top edge and 4 7/8" forward from rear edge of bracket, for antenna lower mounting

bracket. Attach mounting bracket to dash bracket with sheet metal screws.

Drop antenna assembly through hole from top and install nipple at lower end and mounting bracket grommet 6 3/4" from bottom of tube.

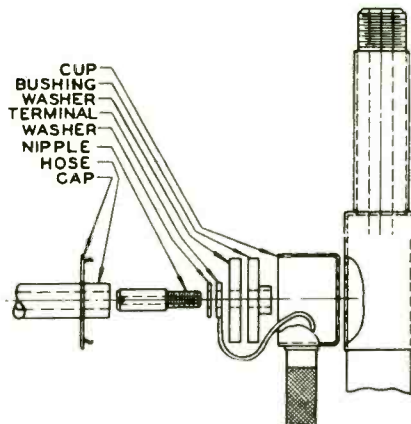

Fig. 2. Details of antenna support and lead-in.

On model 40 production cars hold antenna against mounting bracket and scribe outline of antenna tube on brace. Center punch at center of outline. Raise car off floor and center punch pimple made by punch from the top. Drill with a 1/8" drill and complete hole with 1" cutter. Also drill a 1/2" hole for vacuum tube 1 1/2" forward of this hole. On other

RED-CAPS
SPEED SERVICING

Smaller diameters . . .
as few as 12 condensers cover
most repair requirements.

Stock these new, smallest
dry electrolytics . . .
build your own filters!

RED-CAPS for Service — today!

Write for Bulletin R-C

SOLAR MFG. CORP., Bayonne, N. J.

THOUSANDS of ITEMS
for **MANUFACTURERS, JOBBERS and SERVICE MEN**
ARHCO

These are but a few of the many thousands of items we manufacture . . . many are sold under "private brand" names.

It pays to stock ARHCO display boards . . . merchandise moves faster, sells itself and increases unit sales.

A complete source of supply

AMERICAN RADIO HARDWARE COMPANY, INC.
476 BROADWAY
NEW YORK, N. Y.

Contact your Jobber or write for free literature

1940 models sufficient clearance eliminates this operation.

File rough edges from these holes and make sure that there is free clearance and holes are in line and drop antenna through bottom hole just drilled.

Install 3/4" hose to nipple at bottom of antenna tube and carry hose through hole drilled.

Place lead-in cup, bushing, washer, lead-in terminal and small washer in position over upper nipple hole in antenna tube and install nipple. (See Fig. 2) The nipple is used to hold these parts to the antenna.

Slip lead-in snap cup over 1/4" hose and install hose to this upper nipple.

Fig. 1. Template for mounting antenna to car. This may be enlarged to correct size by copying off on stiff paper marked off in half-inch squares.

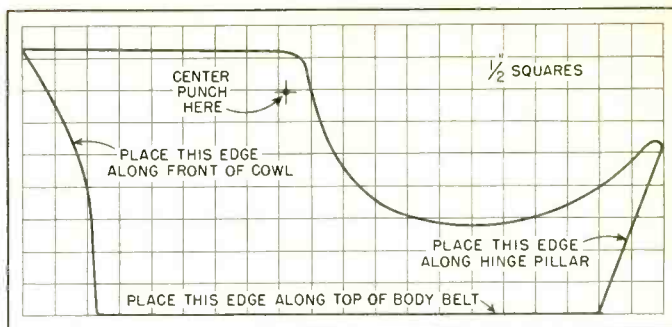

Place flat steel washer and soft rubber collar on neck of antenna and push neck of antenna up through hole in cowl. Install flat rubber washer, hard rubber collar, chrome washer and nut on upper end of antenna. If there is not sufficient tube thread length to provide full thread on antenna for nut remove parts just installed and trim off the lower end of the soft rubber collar as required. Reinstall parts in order named. Be sure antenna has proper clearance over its entire length. Misalignment will cause binding and prevent free operation.

Attach lead-in ground "pigtail" to cowl drain channel as close to lead-in as possible, using a #8 sheet metal screw. A 1/8" hole will have to be drilled.

Locate and drill a 1/8" hole on left side of instrument panel directly opposite and at a distance of 7/4" to left of speedometer trip mileage window. Complete with 1/2" drill. On models other than 1940 drill hole 2/8" directly below headlamp beam indicator.

Install control valve, washer and nut and tighten nut securely.

Install lower hose (3/4") to valve nipple nearest to control button and upper hose (1/4") to valve nipple at extreme end of valve.

Cut windshield wiper hose 3" below wiper connection. Install ends of hose just cut over end connections of tee supplied in kit. Attach antenna hose (27") from side connection of tee to center nipple of control valve.

CHECKING OPERATION

To check operation, start motor; when button is pushed in, antenna should move up freely; when button is pulled out, rod should drop down. Operation of the antenna should be smooth and free. If not, check alignment of tube in car and be sure there is no binding of the tube to cause rod to bind inside the tube. If this does not bring free release, check the packing gland retainer nut at top of antenna tube. This nut has been properly adjusted at the factory and should not need adjustment, but in case the antenna operates better with the nut slightly loosened this should be adjusted. The nut should not be so tight as to bind.

Fill holes around antenna tube and

vacuum tube at dash brace with "Dum Dum."

Replace silencing pad and cowl side panel.

(Turn to page 32)

*Take it from me
OHMITE parts
do a swell job*



"Yes, sir! I'm free of worries when I install Ohmite Resistors — 'cause I know they stay at work through thick and thin!" It's proved by leading manufacturers of commercial, amateur and broadcast equipment who specify Ohmite units for their products. And by the many Servicemen, too, who make it a habit to say "Ohmite Parts for Me Every Time!"

Visit Ohmite Booth 119 at the Radio Parts Trade Show

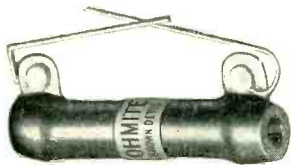

MAIL COUPON NOW!

Ohmite Manufacturing Company
4876 Flournoy Street
Chicago, Illinois
SEND FREE CATALOG 17

Name
Address
City State

OHMITE

RHEOSTATS RESISTORS TAP SWITCHES

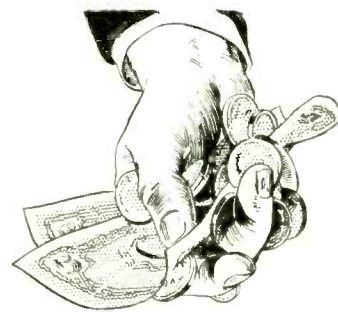

**Just a Part of Your Money
Buys These Low-Priced**

**RELAYS
... BY GUARDIAN**

★ Low priced, because of modern production methods and volume sales, Guardian furnishes relays to thousands of radio builders.

Service Men—Jobbers—Dealers!

Relays by Guardian are famous for ease and flexibility of mounting—famous for compactness and sturdy dependable operation.

Tested under actual operating conditions, Relays by Guardian have proved capable of handling any power up to a K.W. on any frequency up to and including 28 M.C. on A.F. or R.F. circuits.

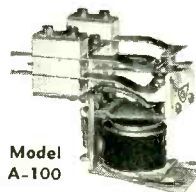

Model A-100

Standard A-100 and A-100-C Antenna Relays AlSiMag insulated operate on 110 V. 60 cycle A.C.

LIST PRICES:

- A-100 Double Pole Double Throw Relay ... **\$6.55**
- A-100-C Single Pole Double Throw Relay ... **\$3.65**
- R-100-G Triple X insulated **\$5.50**

Write for New Bulletin "S" and Free Circuit Diagrams. Order Today!



**GUARDIAN
ELECTRIC**

1633 W. WALNUT ST., CHICAGO, ILL.

Mr. JOBBER!

N.R.P.D.A.

Has an Important

Message for You!

On Thursday, June 13th, 1940 at 7 P.M. at the Stevens Hotel in Chicago, there will be held the First Annual Meeting of the NATIONAL RADIO PARTS DISTRIBUTORS ASSOCIATION.

This will be a Dinner Meeting, for N.R.P.D.A. Members exclusively, immediately after which a Business Meeting will be held. Complete reports will be rendered by your Officers. A feature of this meeting will be an Open Forum which will afford Members the opportunity to express their opinions on the major issues facing our Industry.

You cannot afford to be absent from this important meeting. Use the coupon below and mail it at once to N.R.P.D.A., 5 West 86th Street, New York, N. Y.

It is up to ALL of us to make this meeting a success. Let us set an example to the entire Radio Industry by showing that we can and will solve our business problems through mutual cooperation.

Since it is essential to make the necessary preparations well ahead of the date of the dinner, only Members making reservations in advance can be admitted to this meeting. It is to your advantage to send your check AT ONCE covering reservations for the number of individuals in your organization who will attend.

NOTICE TO NON-MEMBERS

If you have not yet become a Member of N.R.P.D.A. but plan joining this growing group of influential and far-sighted jobbers at Show Time, we suggest that you send your check covering your dinner reservations and request that we send Application for Membership in N.R.P.D.A. (Only enrolled members may attend this dinner.)

MAIL THIS RESERVATION COUPON NOW

N.R.P.D.A.

Arthur Moss, Executive Secretary
5 West 86th Street, New York, N. Y.

Please reserve places at your Dinner Meeting, Thursday
June 13th, 1940, at 7 P.M. Enclosed is my check for \$.....
(\$2.50 per person).

NAME OF COMPANY

ADDRESS

CITY STATE

NAME OF INDIVIDUAL

Mr. Radio Serviceman:

WE WANT TO SEE YOU — At the 3rd Annual RSA Convention • June 14 • Stevens Hotel • Chicago

★ Meet leading figures in the industry. ★ Attend Technical lectures in each subject. ★ Hear and See the F. M. Lecture and complete Demonstration. ★ Attend the R.S.A. Extension School to be held Friday 2:00 to 5:00 P.M., June 14.

★ R.S.A. is the only national organization for radio servicemen, and is accepted and endorsed throughout the industry. The R.S.A. record of achievements is noteworthy. Meet with us and hear our plans for the future.

Write for Your Advance Copy of the Program of the 3rd Annual RSA Convention.

MAIL THIS COUPON NOW!

RADIO SERVICEMEN OF AMERICA, INC.
304 S. Dearborn St., Chicago, Ill.

Name

Address

City State

I am interested in RSA Membership. Tell me about it

I am enclosing \$4.00 for National dues and initiation. Covers dues up to Jan. 1, 1941

(Does not include Local Chapter dues where Local Chapters are organized.) RD-640

Let's Grow Together
In 1940!



RADIO SERVICEMEN OF AMERICA, Inc.

JOE MARTY, JR., EXECUTIVE SECRETARY
304 S. DEARBORN STREET, CHICAGO, U.S.A.

(From page 30)

The antenna has a capacity of 55 mmfd. Therefore, radio should be peaked to the antenna. This should be done by removing the button located at the left side of the control head and adjacent to the antenna lead-in plug. Insert screw driver through opening and adjust antenna compensator screw with receiver tuned to a weak signal on or near 600 kc until maximum volume is obtained. Be sure to balance the radio with the antenna fully extended.

SERVICEMAN'S DIARY

(From page 10)

the motor turn over, but no go. It began to look as if the gears were jammed in some way, so I took off the gear box cover and peered inside. Some soapy water oozed out and splattered on the floor and, incidentally, on my pants. I cursed Jerry for taking the job.

But you could see what was causing the trouble. Apparently a piece of a lace handkerchief had become wedged in the gears so they couldn't turn. I pried the teeth around until I could pull out the lace and then switched on the power. Glory be! It worked! And another job was out of the way.

The three remaining calls were easy. Brought in the International midget from

one place, poked a new 25L6-G in another midget, and made a date to put up a new aerial at the last place. Perhaps I should have done the job right away, but, after all, it was lunch time and, well, you know how it is!

CIRCUIT COURT

(From page 19)

receiver (Stromberg-Carlson Model 480) is shown in Fig. 3.

Perhaps you may have wondered about the reason for the resistor *R* shown in the circuit. This serves the very necessary purpose of providing a proper termination for the whistle filter. In such filter networks, if the impedance at the input differs radically from that at the output, transient oscillations may develop

which result in chirps which tend to distort speech.

When the filter is properly terminated, proper filter action is obtained. If the output impedance is too high, the signal is reflected back into the circuit, causing the spurious effect described above. So, if you run into such a peculiar type of distortion, don't fail to check the filter terminating resistor.

CORRECTION NOTICE

In the advertisement of the National Union Radio Corporation on a Battery Merchandiser, appearing on page 23 of the May issue, the line "deposit refunded on purchase of 43 points" should have read "deposit refunded on purchase of 430 points".

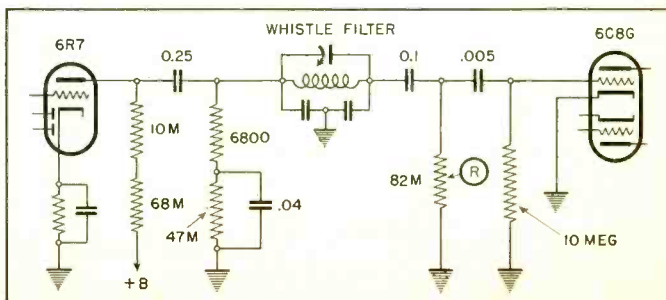
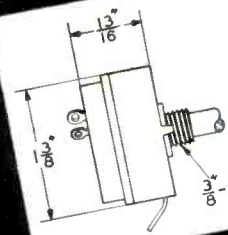

Fig. 3. Whistle filter circuit in Stromberg-Carlson 480. Resistor *R* is the termination impedance.

The CENTRALAB Family

of VOLUME

CONTROLS



STANDARD

Long famous for the reliability of Centralab's non-rubbing contact and long wall type resistor. Available plain, or with one, two, or three taps, and with SPST, DPST, or SPDT Underwriters Approved switches.

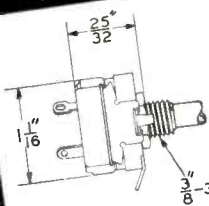

MIDGET

Small in size, but large control efficiency due to the long straight path of the wall type resistor. Fits well in crowded chassis as solder lugs do not project far beyond the control radius of 17/32". Available single, dual, or triple, plain, or tapped, with SPST, SPDT, DPST, and a special dial lite push switch for battery sets.

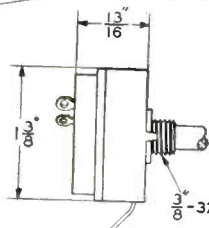

WIRE WOUND RADIOHM

Identical in size and appearance with the Standard Radiohm except has brown colored base. Resistances range from 2 ohms to 10,000 ohms. Rating 3 watts. Furnished plain or with SPST, SPDT, or DPST Underwriters Approved switches.

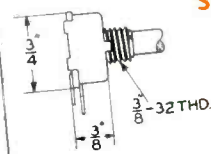

SUB-MIDGET

The smallest diameter reliable control. Long wall type resistor gives low noise level. Rapid Transfer of heat from resistor to metal shell gives maximum load rating of 1 1/2 watts. No switch or taps. Available as grounded or insulated rheostat or potentiometer with solid or tubular shaft.

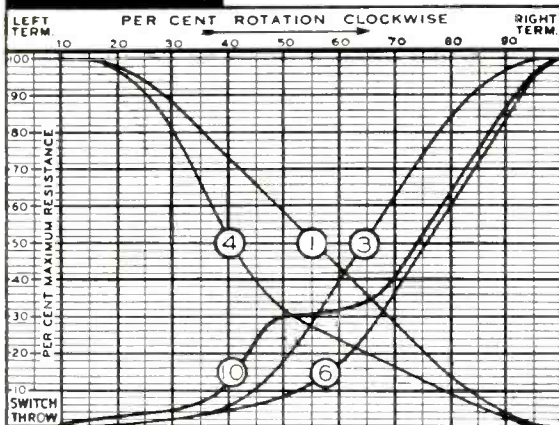

The resistor curve of a volume control is more important than its overall resistance... that is why Centralab controls are furnished with the variety of curves shown here. Curve six is most widely used for high resistance radio grid and diode controls. Curve 1, or 4, are best for C bias, and Curve 3 for antenna C bias. Curve 10 is used on tapped controls.

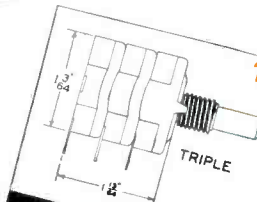

TWIN AND TRIPLE CONTROLS

Two or three sections assembled in tandem for special purposes. Each section fully shielded and has independent connections. All variable contacts attached to a single shaft. Twin controls also available with concentric shafts; one inside the other. Supplied with or without Underwriters Approval snap switches.

All controls furnished with any desired maximum resistance and with appropriate tapers. Control and resistor problems melt away when you put Old Man Centralab on the job.

Centralab

CENTRALAB • 900 E. KEEFE AVE • MILWAUKEE, WISCONSIN
A Division of GLOBE-UNION INC. Cable Address: Centralab Milwaukee

HERE'S WHY WARD AERIALS

give you the edge over competition!

SIDE COWL ANTENNAE with CERAMIC or BAKELITE Stanchions

Features in Ward side-cowl antennae are Low-loss ceramic or sturdy bakelite stanchions — with parts necessary to adapt upper stanchions to Chrysler or Torpedo bodies at no extra cost.

(Left) Upper stanchion (ceramic) adapted for Torpedo or Chrysler body.

(Below) Showing simple conversion for upper stanchion.

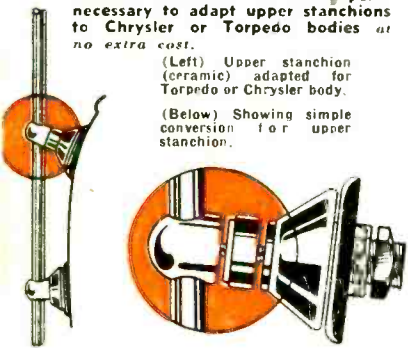

WARD FLEX-ANGLE



Fits All Contours

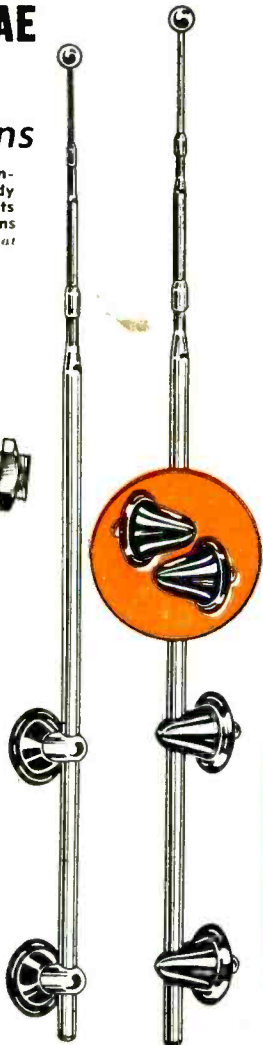

List prices for complete aeriats—
Bakelite \$2.75 up Ceramic \$2.95 up

● The 1940 Ward Line of Aerials is brimful of extra values, exclusive features and effective "sales clinchers" that enable you to dominate competition on price, quality and performance. Compare it item for item, feature for feature and dollar for dollar with anything on the market. You'll see quickly why Ward Products GIVE YOU THE EDGE!

WARD Signal Boosters—Z-Match Units

Service Dealers can make extra sales and profits by selling Ward Booster units—giving their customers greater signal strength. Variable and fixed Z-Match units with high permeability iron core. List prices—Variable \$1.95, Fixed \$.75

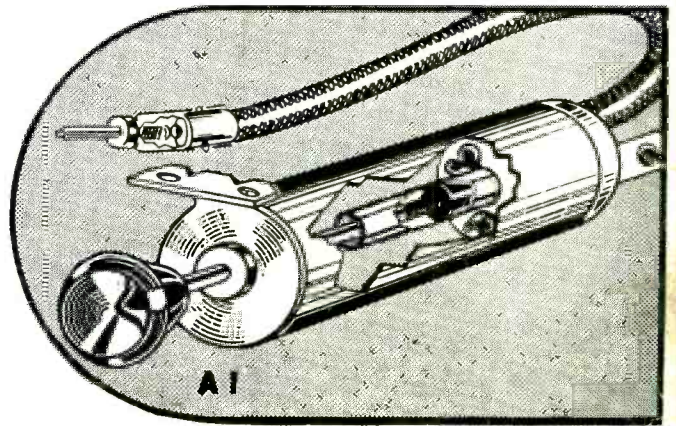

See us at the
PARTS SHOW
Booth 922-924

WARD PRODUCTS CORP.
205 Ward Building—Cleveland, O.

Please send me your 1940-41 catalog, and let me know how I can get my share of these profits.

NAME

ADDRESS

CITY & STATE

Dealer Jobber

- WARD PRODUCTS CORP. -
205 WARD BUILDING CLEVELAND, O.

<p>Only Ward leads with Hydro-Seal can withstand this test. Ordinary loom leads will leak.</p>	<p>Ward lower cowl stanchions, whether ceramic or bakelite are designed to give complete shielding.</p>	<p>Ward EZ-IN plug with silver positive contacts and low-loss ceramic stanchions</p>	<p>Try the smoke test on ordinary loom leads and prove to yourself that only Ward has water-proofed leads.</p>

Water-Proofed-Tip to Input
HYDRO-SEALED LEADS AND STANCHIONS